

# Inside F5J

## Assembly Manual



Original work in German by GRÜNER CNC Service, all rights reserved 2015.  
This version is published with the expressed permission of GRÜNER CNC Service.

Download the [original document here](#) with full illustrations.

Translation to English by the following contributors:

- Fabien Gagné (FabFlight), Canada
- Christopher Kerrigan (Cricklewood), Canada
- Dario Ernst (NebuK), Karlsruhe, Germany
- Anthony Eden (aerotony), Australia

Grüner can not be held liable for consequential damages that may arise during the operation of products from our product range.

Observe all notes intended for use (addendum).

No liability for misprints.

The reproduction of texts and text extracts, drawings and pictures is only allowed with our express written permission.

## **Building instructions**

Thank you for choosing a quality product MADE IN GERMANY.

Please read these building instructions and suggestions prior to construction, then carefully proceed with the step by step construction.

## **PRESENTATION OF THE MODEL**

The INSIDE F5J is the aileron version of the Introduction F5J.

The wings are constructed in three sections with carbon tube spars.

The wing joiners are built into the spars.

The wing profile used is the AG35.

The fuselage sides are reinforced with braces and stiffeners.

Wing ribs are pre-cut to accept the carbon spars.

The tail feathers are built-up from trussed balsa parts.

The system is designed to use ORACOVER<sup>1</sup> for the wings and fuselage, and ORALIGHT<sup>2</sup> for the tail feathers.

Due to the long nose and lightweight drive components, balancing the tail is as easy as possible.

Specific glue icons are shown in the relevant sections of the building instructions (NOTE: In this English translation, the type of glue is specified between parentheses instead). For superglues we recommend using normal cyanoacrylate (CA) and thick cyanoacrylate (thick CA, with a slower set time).

## **TOOLS AND ADHESIVES**

- Modelling knife, small balsa plane, sanding paper 100 and 180 grit, small round file, small drill and Ø2.0 and 5.0 mm bits, fine metal saw, soldering iron, covering iron.
- Thin CA (ZAP)
- Thick CA (SLO-ZAP)
- 5 minutes two-components epoxy (ex. UHU plus Schnellfest)
- 90 minutes two-components epoxy (ex. UHU Plus Endfest)

## **DRIVE**

Motor: (Premium) Hacker A20-22L evo, (Standard) Roxxy 2834/12

Battery: 3S 1800mAh, 150 g

Propeller: 11x6 CAM Carbon folding-prop

---

<sup>1</sup> Other brands: Ultracote, Profilm.

<sup>2</sup> Other brands: Ultracote Lite, Profilm Light.

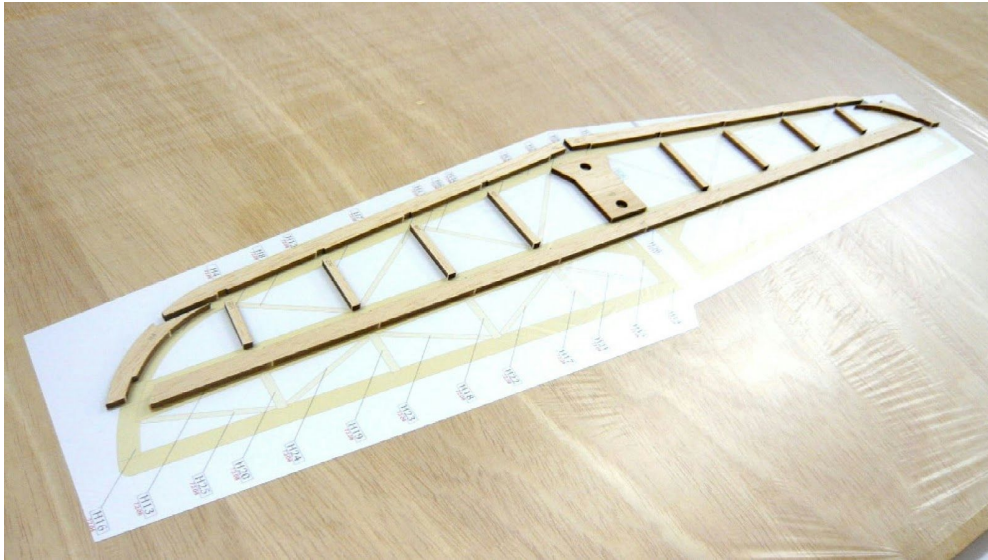

# 1

Sheet 72.08  
Parts H1-H8

- Cut out the plan and cover with transparent film (cling wrap film or polyethylene).
- Glue together the tailplane parts H1 to H8 (thick CA).

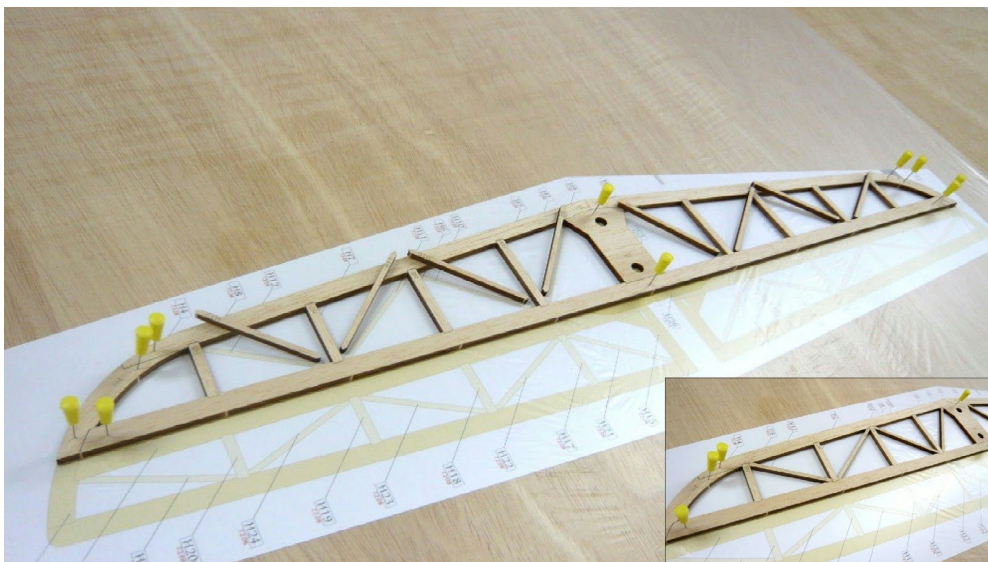

# 2

Sheet 72.08  
Parts H9-H12

- Check the fit of diagonal braces H9 to H12 and glue into place without warping the frame (thick CA).

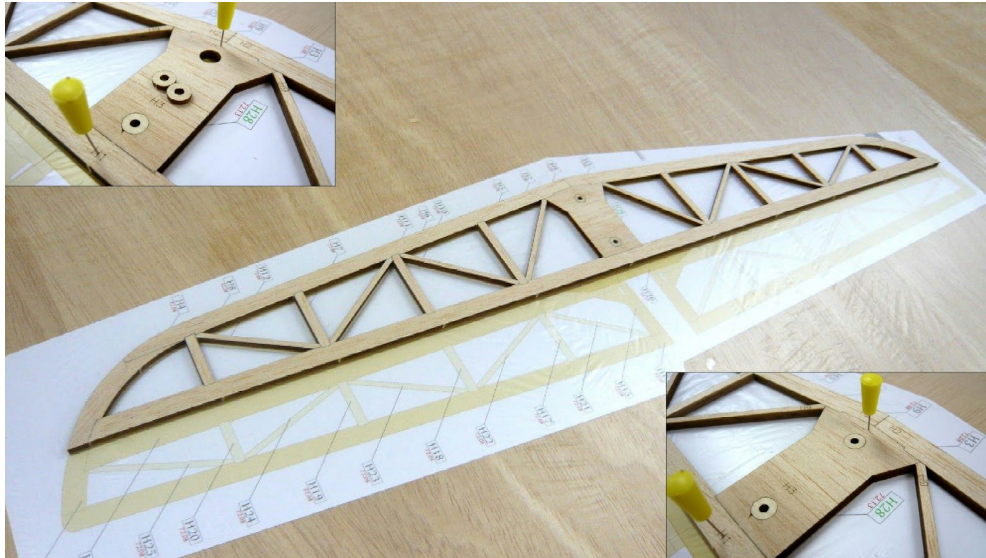

# 3

Sheet 72.13  
Part H28

**NOTE:** This step is only required if building a removable elevator.

- Glue ply pieces H28 in the holes of the centrepiece H3 (thick CA).

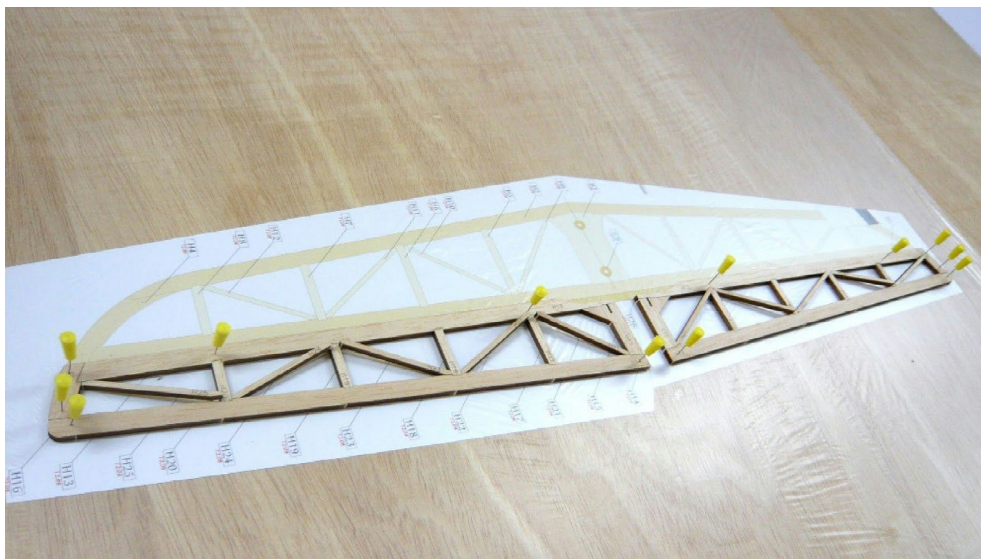

# 4

Sheet 72.08  
Parts H13-H25

- Glue the elevator parts H13-H20 (thick CA).
- Check fit then glue the diagonal braces H21 to H25 without warping the frame (thick CA).

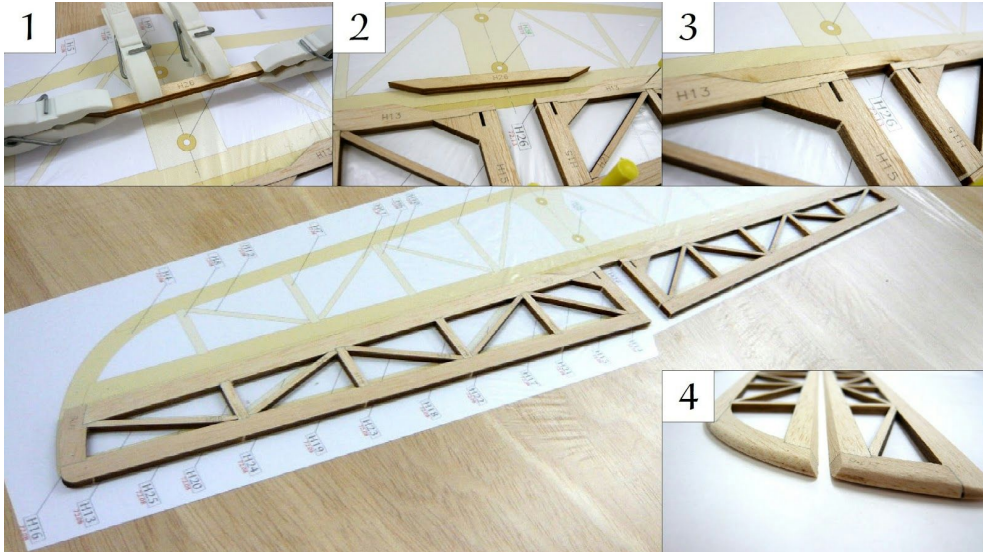

# 5

Sheet 72.13  
Part H26

- Figure 1. Glue together (stack) the two plywood elevator connectors H28 (thick CA).
- Figure 2 and 3. Glue the connectors to the centre of the elevator (thick CA).
- Figure 4. Sand the tailplane and elevator according to the sections shown on the plan.

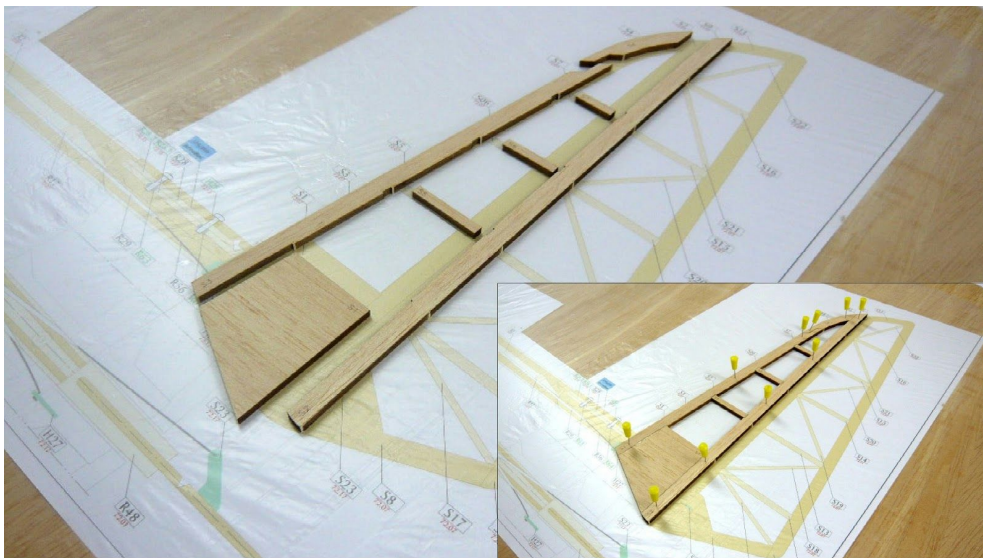

# 6

Sheet 72.07  
Parts S1-S7

- Glue the rudder parts S1 to S7 (thick CA).



# 7

Sheet 72.07  
Parts S8-S16

- Glue the rudder parts S8 to S16 (thick CA).

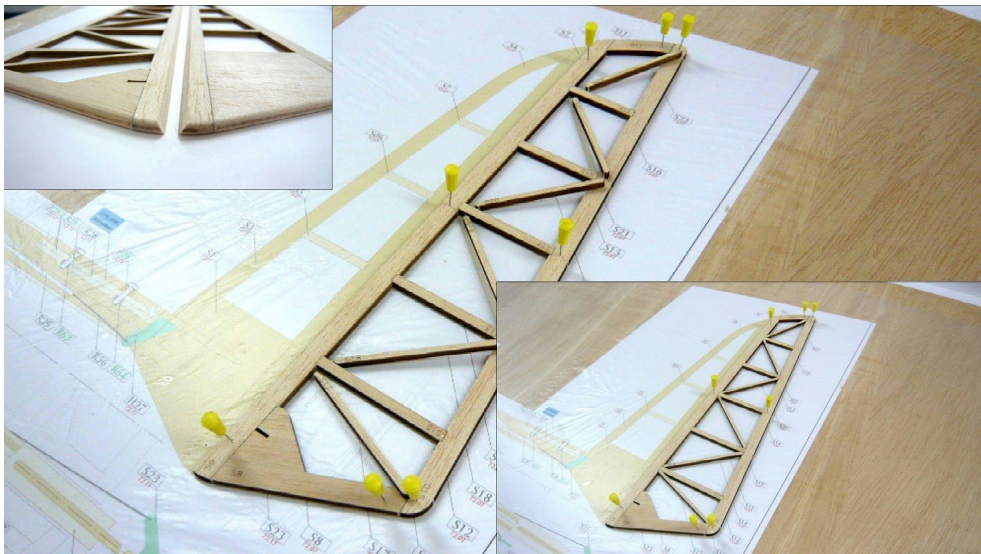

# 8

Sheet 72.07  
Parts S17-S22

- Check fit then glue the diagonal braces S17 to S22 without warping the frame (thick CA).
- Sand the rudder to the sections shown on the plan.



# 9

Sheet 72.02  
Parts R1, R2

**NOTE:** In the following phases be sure to make one left-handed and one right-handed fuselage side.

- Glue the front and rear side portion of the fuselage walls R1 and R2 (thick CA).
- Cut out/file out the slots for the pushrod sleeves in the left-hand fuselage side in front of the drilled hole, and behind the drilled hole in the right-hand fuselage side.

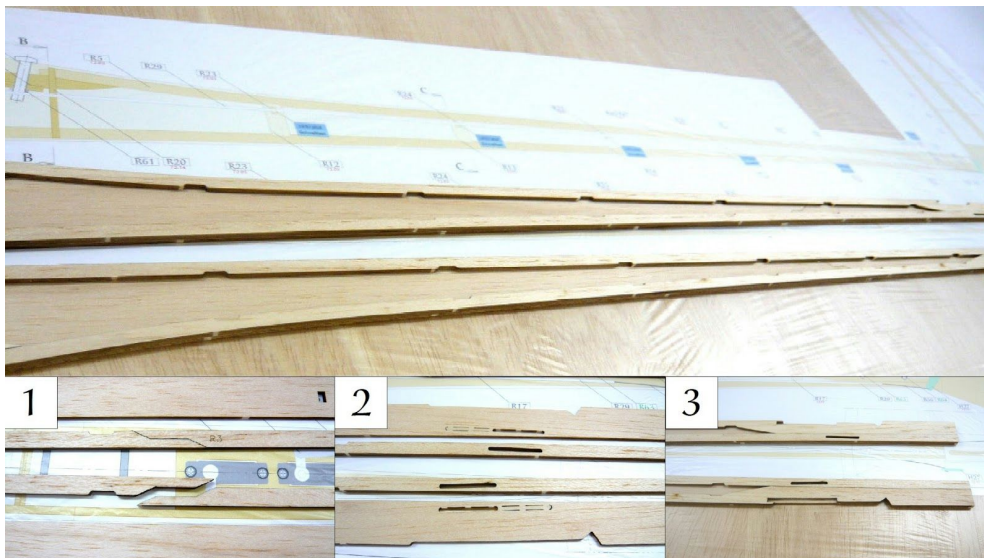

# 10

Sheet 72.05  
Parts R3-R5

**NOTE:** Build experience from the EN translators suggests to perform the following three steps in reverse order.

- Glue together the lower fuselage doubler parts R3 (front) and R4 (rear) (thick CA).
- Glue the lower fuselage doublers R3/R4 flush with the fuselage side (thick CA). Beware of the pushrod hole position.
- Glue the upper fuselage doubler R5 flush with the fuselage edge (thick CA).

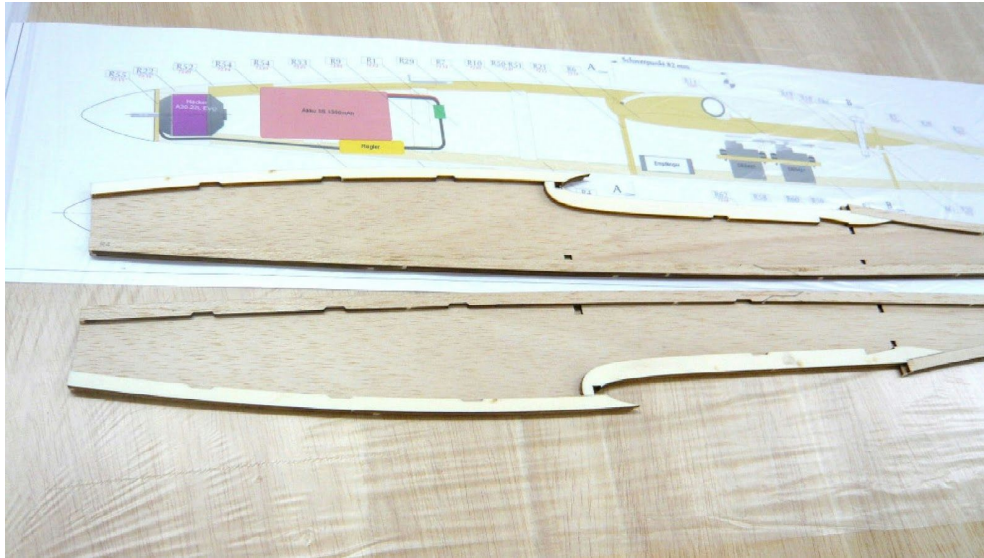

# 11

Sheet 72.14  
Parts R6, R7

- Glue the wing-bed doubler R6 and front fuselage doubler R7 flush with the fuselage edge (thick CA).



# 12

Sheet 72.05  
Parts R8-R17

- Glue the stiffeners R8 to R17 (thick CA).
- **NOTE:** Pay attention to the orientation of the slots in R12 to R16 (to accept the fuselage stiffeners R23 to R27 in step 19). The slot in R16 is reversed compared to the slots in R12 to R15. This is to ensure correct alignment of the push-rod sleeves and smooth running of the push-rods.





# 13

- Clamp both panels together and sand the outer edges.

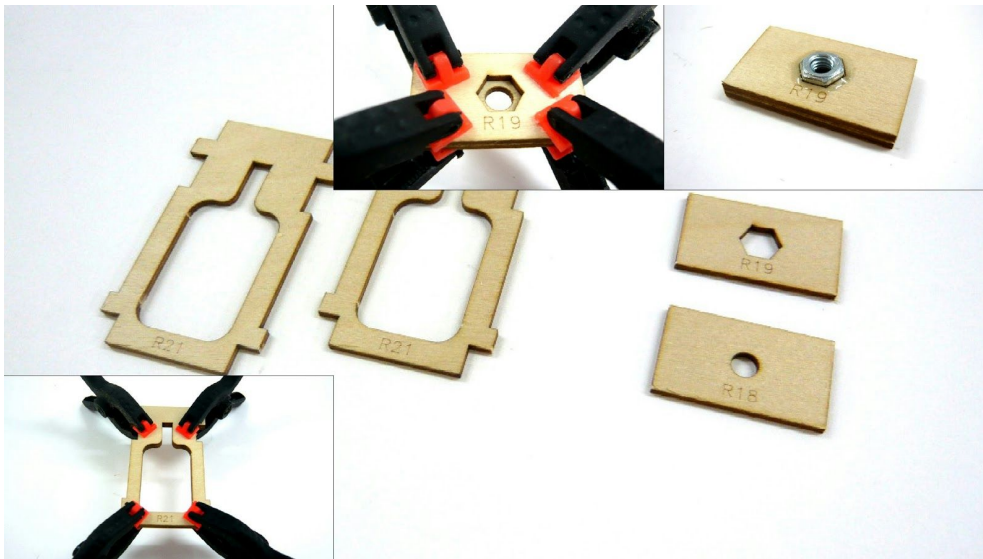

# 14

Sheet 72.13  
Parts R18, R19,  
R21

Small parts bag  
Part R61

- Align and glue together (stack) both R21 parts using clamps (thick CA).
- Align and glue together (stack) R18 and R19 using clamps (thick CA).
- Glue the nut R61 using epoxy (5 minutes epoxy).  
**WARNING:** Ensure no glue gets into the threads.

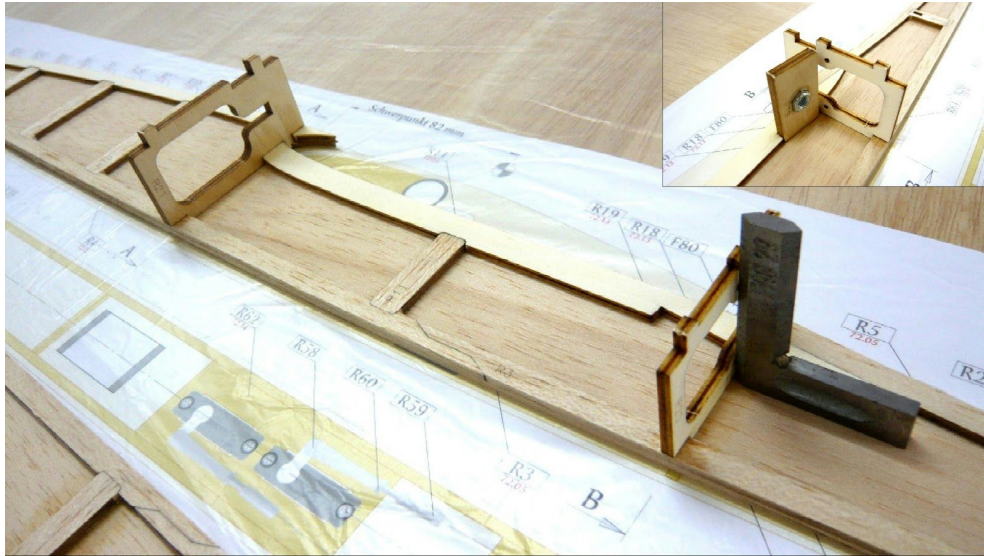

# 15

Sheet 72.14  
Part R20

- Glue the wing saddle R18/R19 at right angle (5 minutes epoxy).
- Glue the R20 and R21 ribs exactly perpendicular (thin CA).

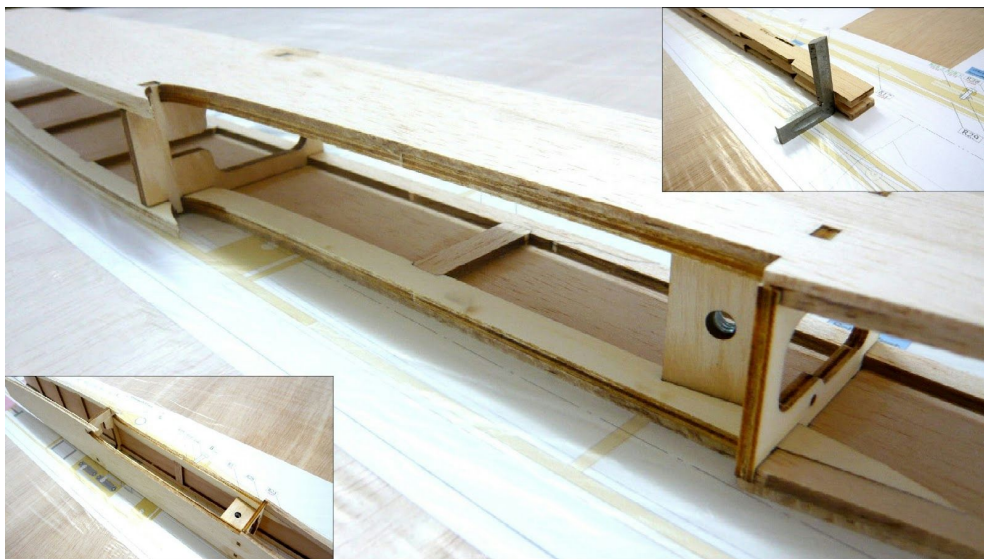

# 16

- Glue the second fuselage sidewall assembly. Use the same adhesives as in step 15.
- Check with a right angle that the fuselage sides are properly aligned with each other.



# 17

Sheet 72.16  
Part R22

- Glue the nose block R22 (thin CA).
- For this purpose make the fuselage with nose block perpendicular to a surface and apply the adhesive on the inner surfaces of the side parts.
- The adhesive can penetrate the nose block, so perform this task installed over a plastic film.

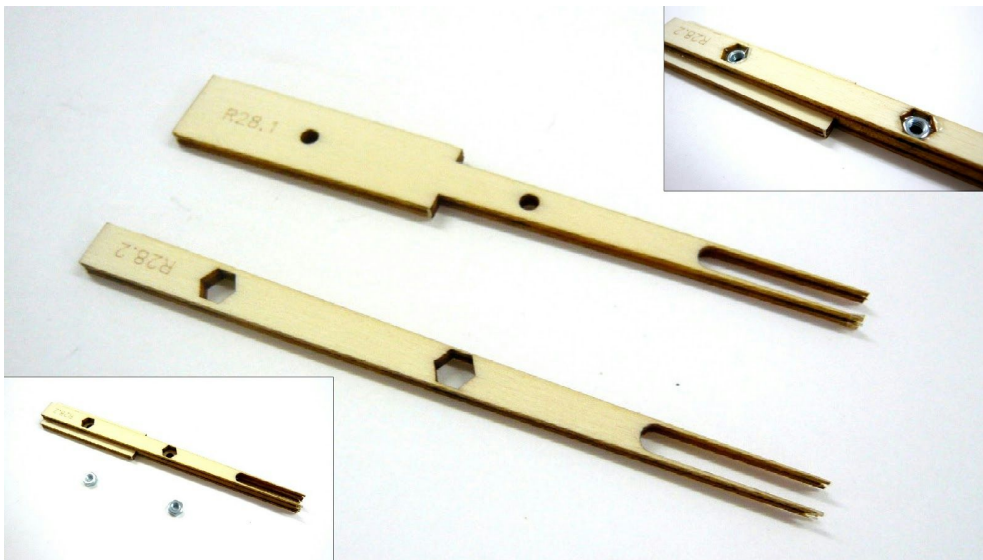

# 18

Sheet 72.05  
Part R28

OPTION detachable  
tailplane

Sheet 72.14  
Parts R28.1,  
R28.2

**NOTE:** The building step shown here describes the tail holder for a DETACHABLE elevator.

- If a non-removable elevator will be installed, use balsa part R28 from sheet 72.05 to save weight.
- Glue part R28.1 centrally to part R28.2 (thick CA).
- Glue the nuts R63 in place (5 minutes epoxy).

**WARNING:** Ensure no glue gets into the threads.



# 19

Sheet 72.05  
Parts R23-R27

- Glue the pushrod sleeve guides R23 to R27 into the slots in R12 to R16 (thin CA). Use the plan, protected by transparent film, as a guide to ensure that the fuselage is straight and that the fuselage sides are vertical.



# 20

- Still over the plans, covered with plastic wrap, glue the tail holder from step 18. Make sure the fuselage is straight and true (thick CA).
- File/sand a V-shaped slot opening (see marking in the small picture) to provide free movement for the elevator connector. When making a non-removable elevator, you will sand through this part a bit. However, this is not critical.



# 21

Small parts bag  
Part R29

- With a thin round file (mouse tail file) or a 2 mm drill bit, rework the slots for the pushrod guide tubes.
- Install the guide tube R29 and check the smooth running of the pushrod wire R56.
- Glue the guide tubes (5 minutes epoxy).



# 22

- Sand the fuselage ribs flush to the fuselage side parts.

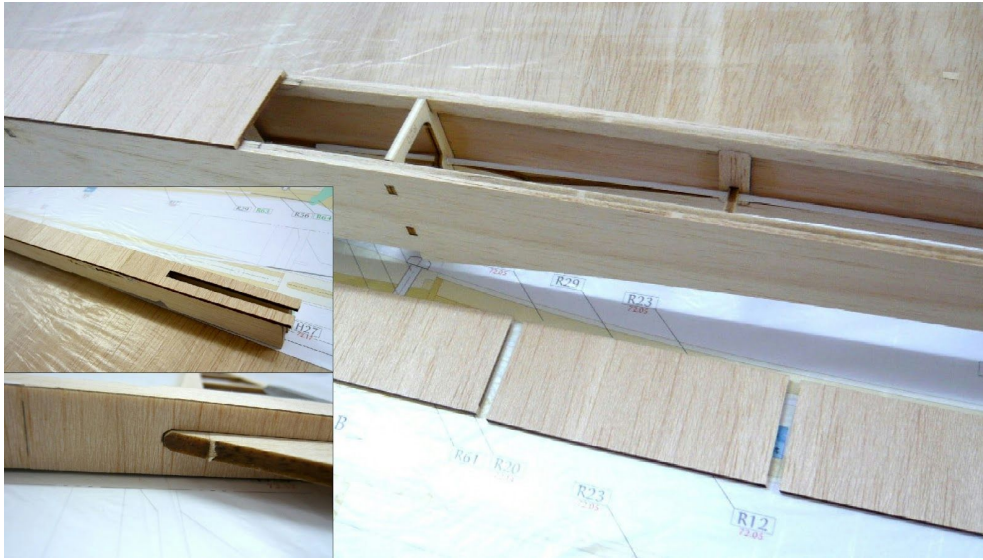

# 23

Sheet 72.01  
Parts R30-R39

- Glue bottom fuselage sheeting (parts R30 to R39) (thick CA).
- Adjust the cut-out for the rudder on part R39 to the fit the rudder.

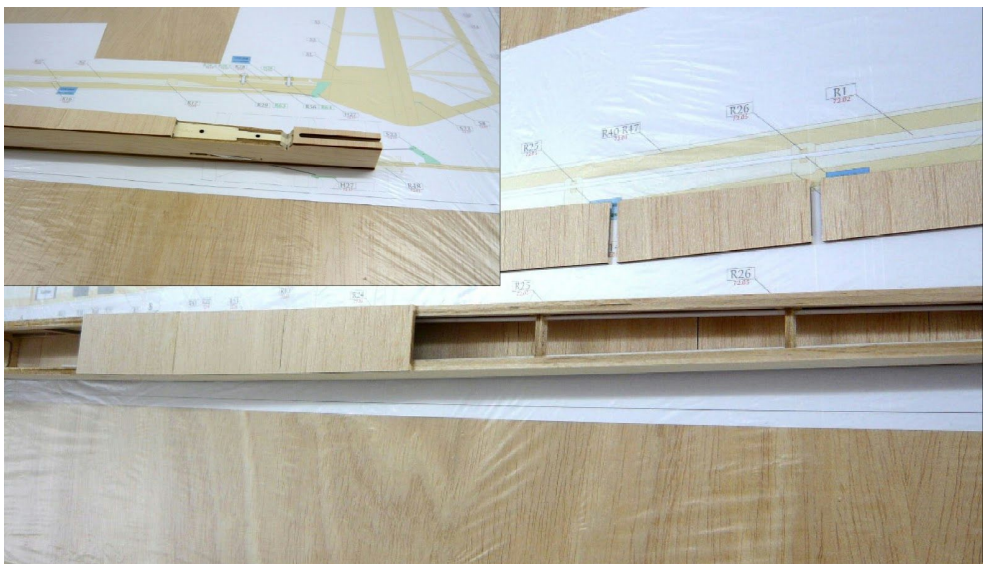

# 24

Sheet 72.01  
Parts R40-R48

- Glue the top fuselage sheeting parts R40 to R48 (thick CA).
- **NOTE:** Be careful that the fuselage does not warp/twist.

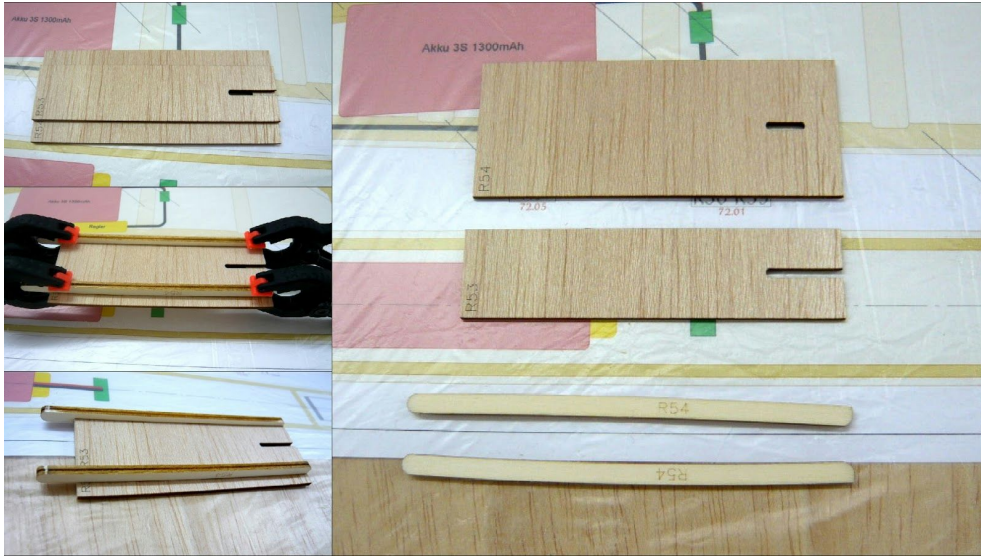

# 25

Sheet 72.01  
Parts R53a, R53b

Sheet 72.14  
Part R54

- Glue the doubler of the battery flap R53.2 exactly centered on the part R53.1 (thick CA).
- Glue the side-rails, R54 on both sides of R53 (thick CA).  
The battery hatch cover should fit easily into the fuselage cutout.

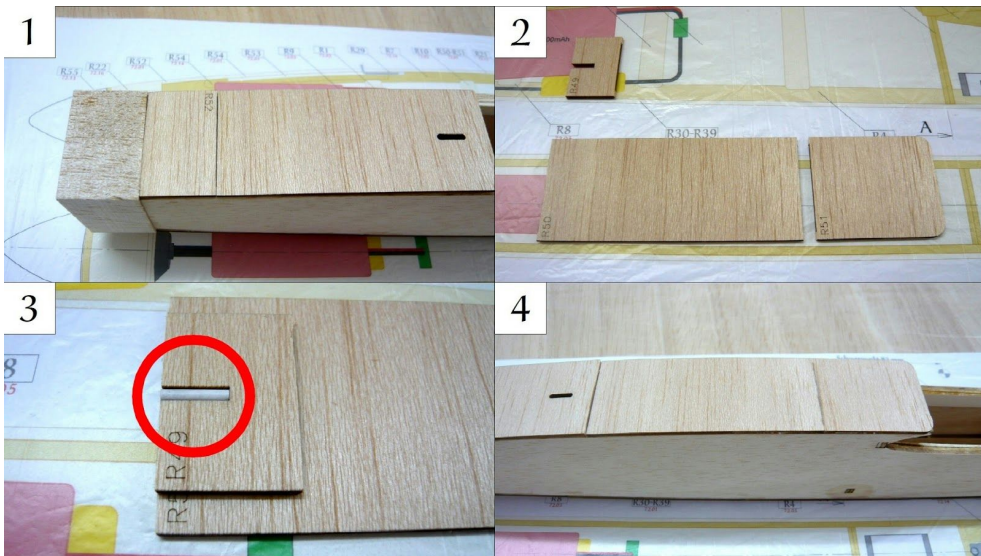

# 26

Sheet 72.01  
Parts R49-R52

Long parts bundle  
Part R56

Small parts  
Part R65

- Glue the front fuselage skin R52 (picture 1) (thick CA).
- Glue the top sheeting R50 and R51 together at the abutting edges (pict. 2) (thick CA).
- Glue the holder R49 front flush and centered on the sheeting R50 (pict. 3) (thick CA).
- The hatch cover can be retained by either a wire or magnetic closure. For the wire closing, use a short piece of guide tube R29. For the magnetic closure, glue a bar magnet R65 in the cap holder (picture 3). The magnet in the battery compartment should only be glued after covering with covering film — and verifying the polar direction. (5 minutes epoxy)
- Slide the hatch cover in the fuselage. Leaving a 0.5 mm gap between the hatch cover and R50, glue R50 and R51 to the fuselage (thick CA).

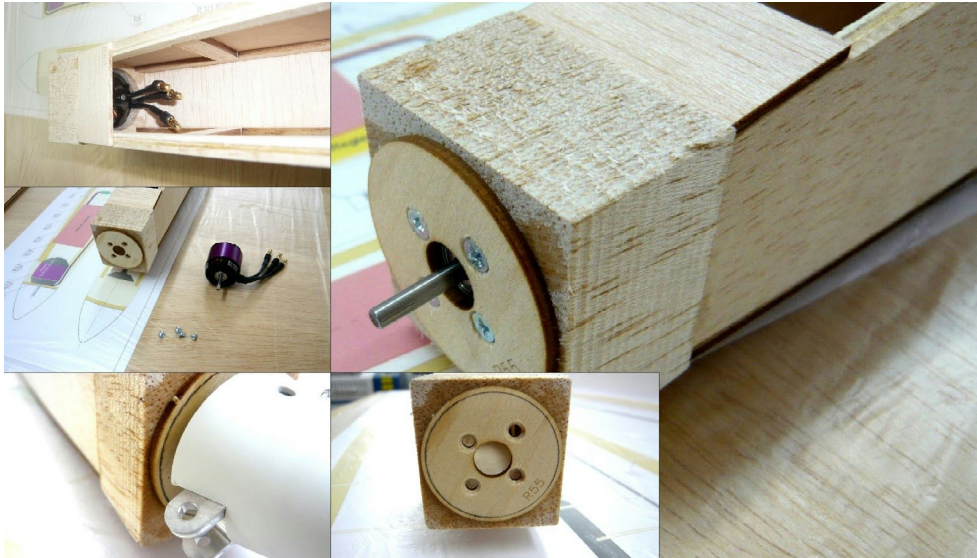

# 27

Sheet 72.13  
Parts R55

- Screw the motor to the motor bulkhead R55.
- Wrap the motor in several layers of paper so that it fits snugly into the nosepiece. This will ensure that the motor is centered and that the motor will turn freely after gluing the bulkhead.
- Insert the motor and wires into the nose block with the motor bulkhead F55 attached.
- Using a small amount of glue, tack the motor bulkhead R55 to the motor nose block and leave to dry (thin CA).
- Remove the motor, discard the paper, and glue R55 securely to R52 (thin CA).

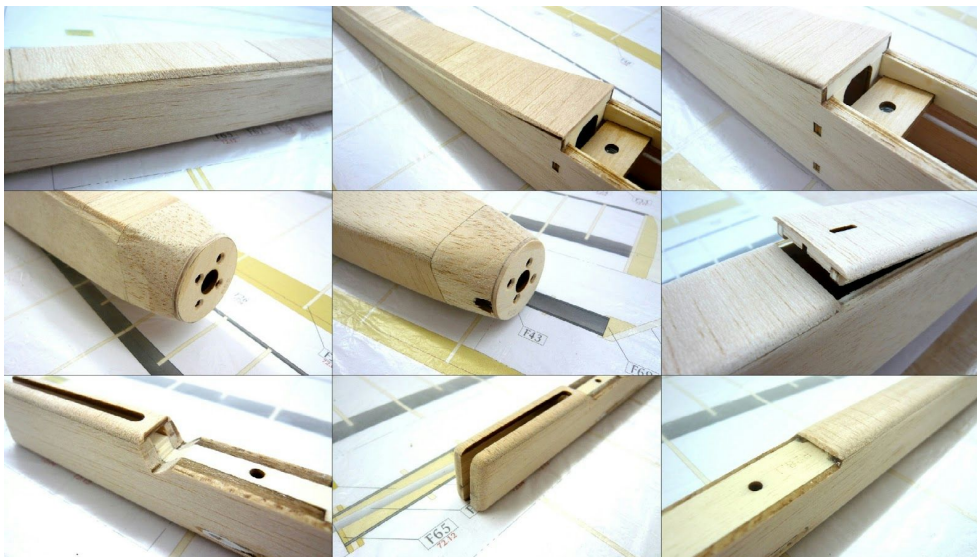

# 28

- Sand the fuselage to round edges, etc., according to cross-section on the plan.





## 29

Sheet 73.03  
Part F4

Small parts bag  
Parts F5, F68

Sheet 73.12  
Part F6

- Glue one F4 to one of F6 rib each, making sure it is flush (thick CA). The locking pin F68 can be used as a guide but do not glue F68 into place.
- Fasten the latch F5 with a little glue (thick CA). **WARNING:** It is important to leave clearance for clip F81, so do not get glue into this space. **NOTE:** The kit contains four clips F81, two of which are spares.
- Glue the second rib F6 and clamp to a straight board until dry (thick CA).



## 30

Sheet 73.12  
Part F3

Sheet 73.09  
Part F2

- Glue the center rib F2 on the plywood rib F3 (thick CA).
- Glue the second plywood rib F3 and clamp assembly to to a straight board to dry (thick CA).

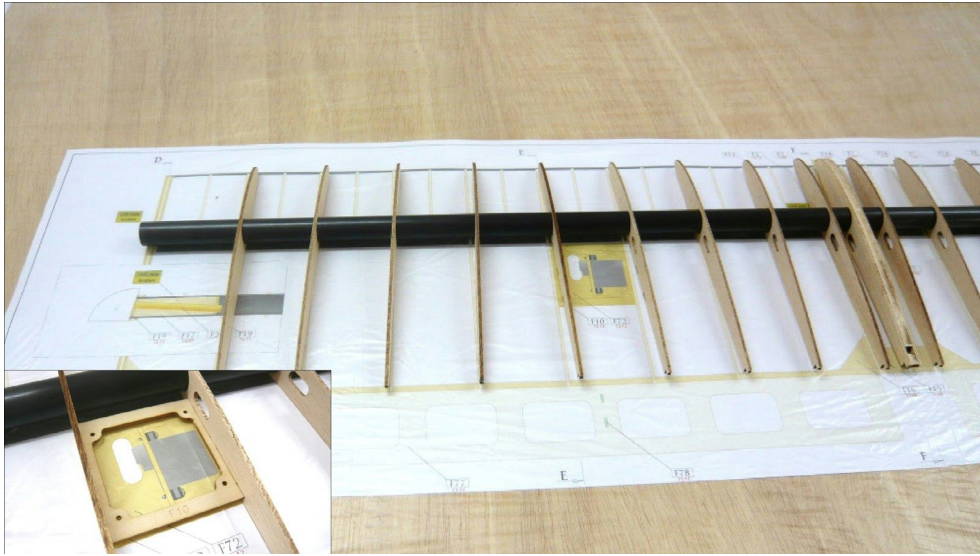

# 31

Sheet 73.03  
Parts F7-F9, F11

Sheet 73.11  
Part F10

Long parts bundle  
Part F1

- Dry-fit the rib combination F6/F4/F6 and all ribs labeled F7, F8, F9 and F11 onto the spar tube F1, according to the plan.
- Insert the servo frame F10 between the ribs F8 and F9.

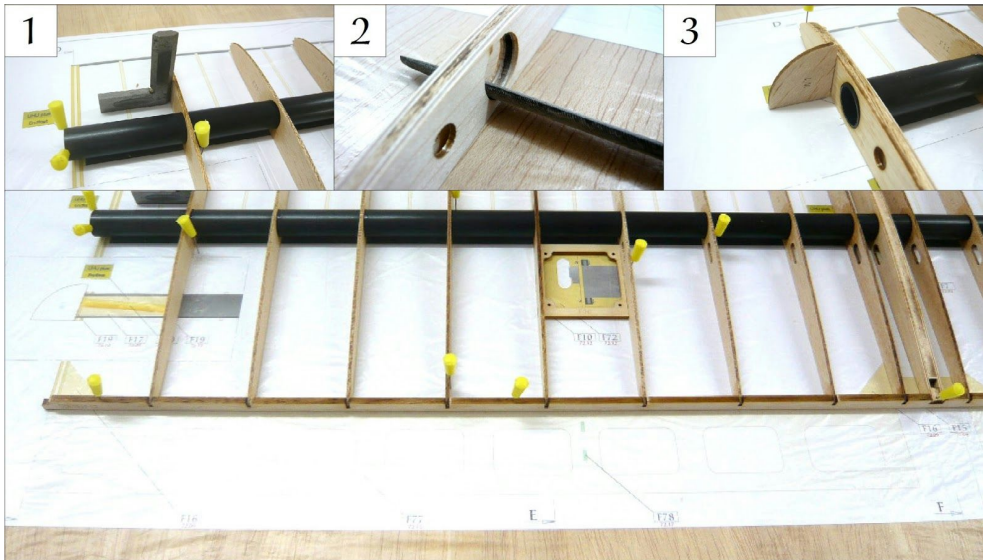

# 32

Sheet 73.10  
Part F12

- Pin the trailing edge F12 over the plan.
  - Gently push the ribs down into the recesses of the trailing edge and align according to plan.
- WARNING:** The flat base of the ribs must rest their entire length on the building board.
1. Align the ribs vertically and glue to spar tube F1 and to trailing edge F12 (thin CA). Use thick CA to fill the gaps if void can still be seen between the spar tube and the ribs. The ribs must be glued around the entire circumference of the spar (thick CA).
  2. Using a small round file, shape the spar cut-outs in the two rib combinations F6/F4/F6 to match the angle template W1, ensuring to shape one left-handed and one right-handed cut-out.
  3. Slide the F6/F4/F6 rib combinations and glue to spar tube F1 using the angle template W1 for proper alignment (thin CA).

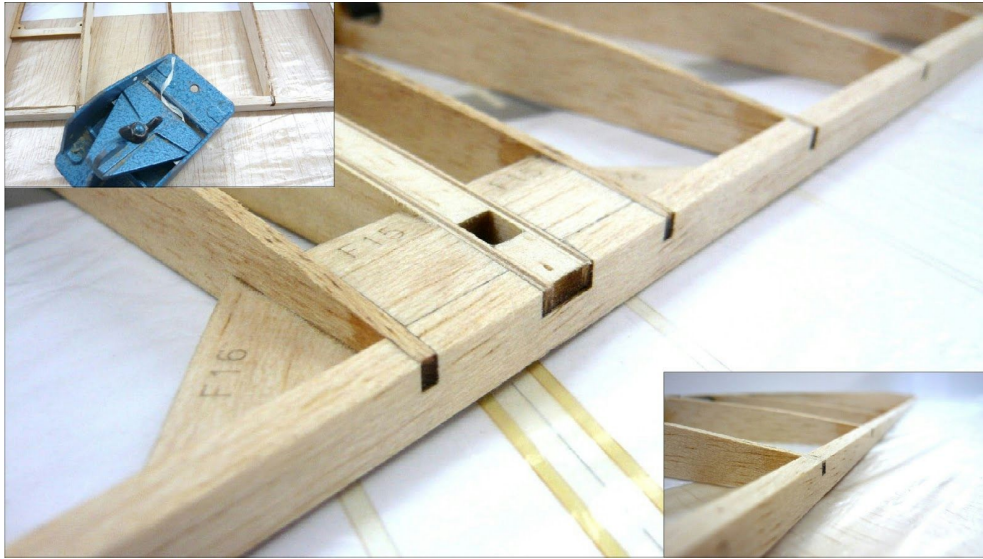

# 33

Long parts bundle

Part F13

Sheet 72.03

Parts F14

- Glue in the leading edge F13 (thin CA).
- Glue in the half ribs F14 (thin CA), aligning them carefully over the plan.

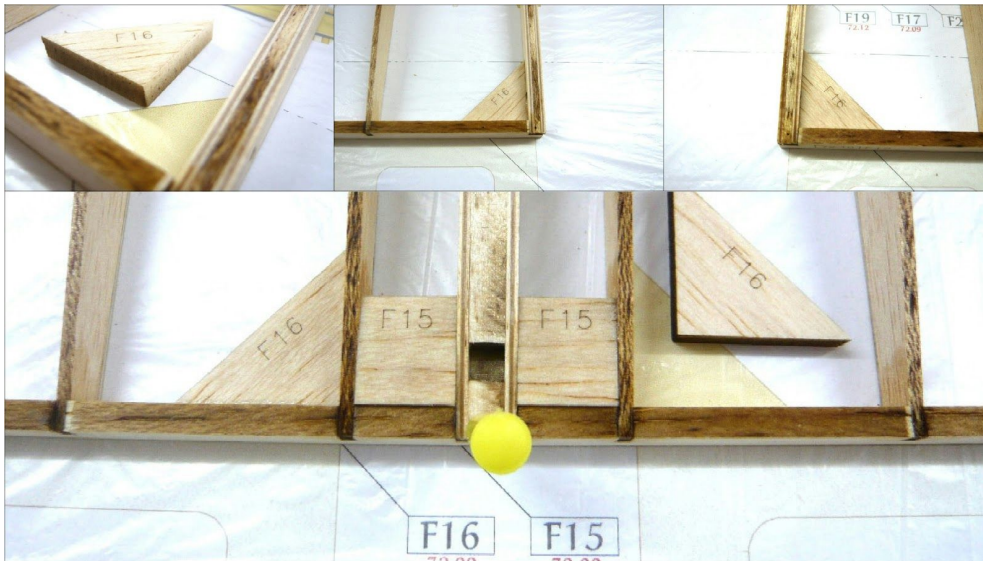

# 34

Sheet 72.09

Parts F15, F16

**NOTE:** All reinforcements are glued flat down on the plan.

- Double up reinforcements F15 (thick CA).
- Check-fit the two doubled F15, trim as required, then glue in (thin CA).
- Glue in the two inboard reinforcements F16 (thin CA).
- Check-fit and trim the outboard reinforcements F16 to match the angle of the combination ribs F6/F4/F6 and glue into place (thin CA).

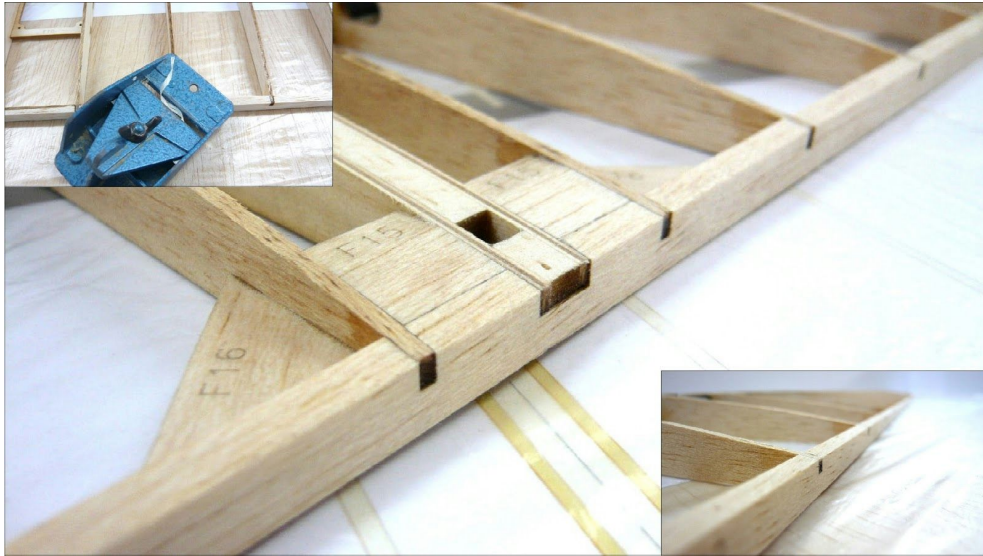

# 35

- Plane the trailing edge to match the profile of the ribs (airfoil) and sand carefully.
- Cut away the excess (length) of the leading edge F13 (the black rod) and the spar (the carbon tube) with a fine metal saw carefully, and sand completely flush.

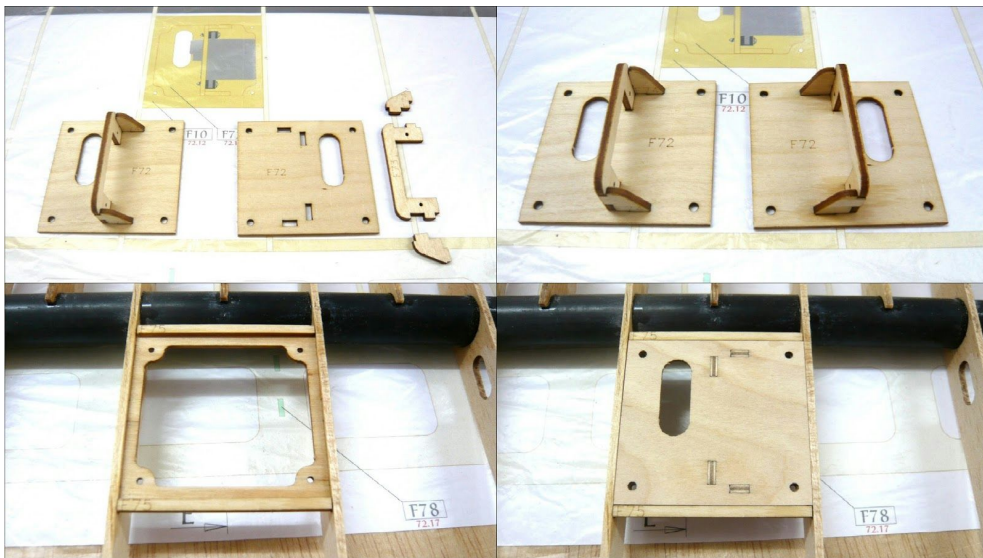

# 36

Sheet 73.13  
Parts F72-F75

- Glue together the servo covers from parts F72, F73 and F74 (thin CA). **WARNING:** Ensure to assemble three left-handed and three right-handed servo covers according to the plan.
- Glue the covering frame cross-member F75 flush with the servo frame F10 (thick CA).
- Sand the complete wing center panel.

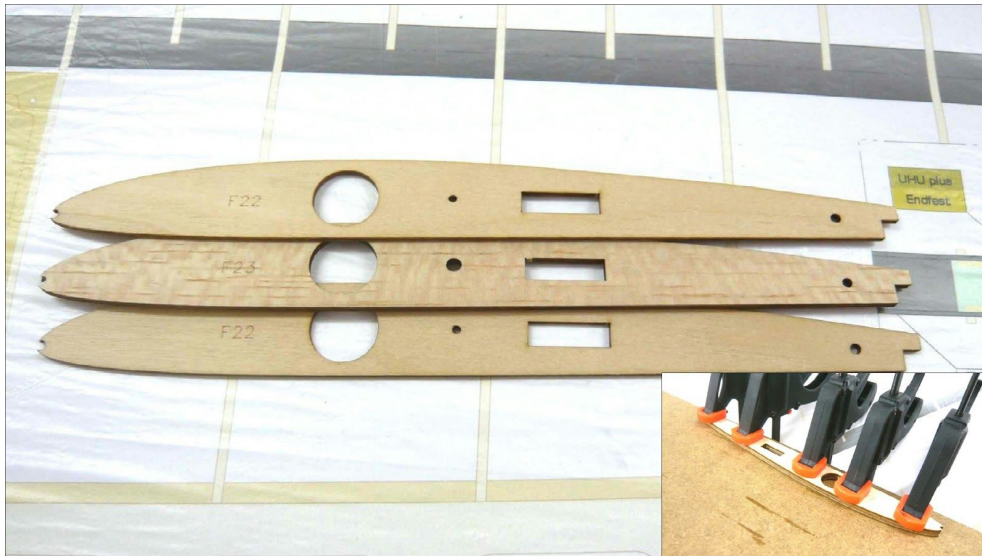

# 37

Sheet 73.12  
Parts F22

Sheet 73.04  
Part F23

- Glue the connecting rib F23 between two F22 ribs. Clamp to straight board until the glue sets (thick CA).  
**NOTE:** This can be done in one or two stages.  
**NOTE:** Pins F68 can be used to align the pieces together but do not glue into place at this time.

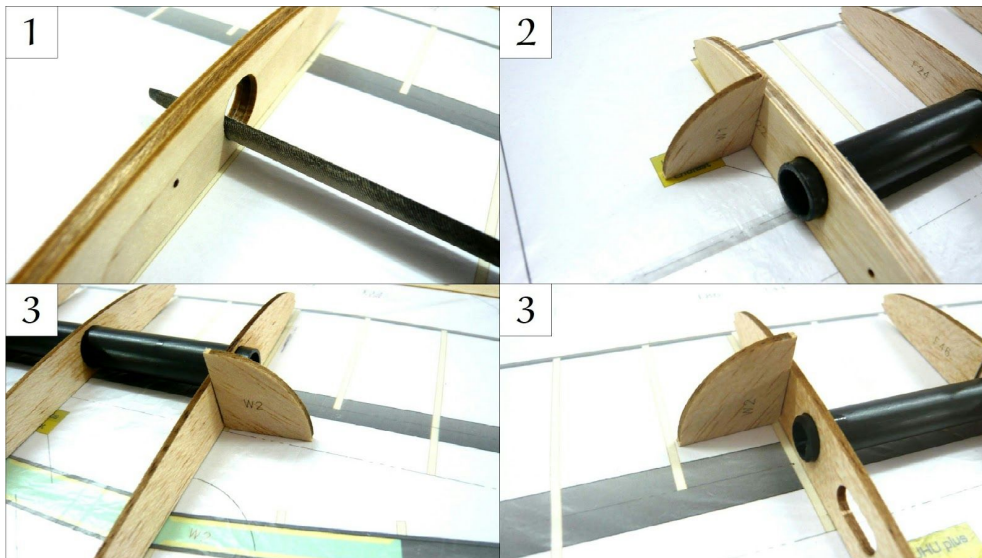

# 38

Sheet 73.04  
Parts F24-F31

Long parts bundle  
Part F21

Sheet 73.10  
Part F33

Sheet 73.11  
Part F10

- Dry fit and slide ribs F24 to F31 onto carbon fiber spar F21.
- Insert servo frame F10 between the ribs F26 and F27.
- Pin the trailing edge F33 over the plan. **WARNING:** Ensure that F33 is correctly orientated. The identification "F33" on the part should be visible, closest to the central wing panel, on the rear face of the trailing edge. The ribs will then correctly match the angled slots in the upper face of F33.
- Align and glue all ribs to the trailing edge strip (thick CA).
- Align all ribs at right angles and glue to the spar (thin CA).
- Glue the servo frame F10 between ribs F26 and F27 (thin CA).

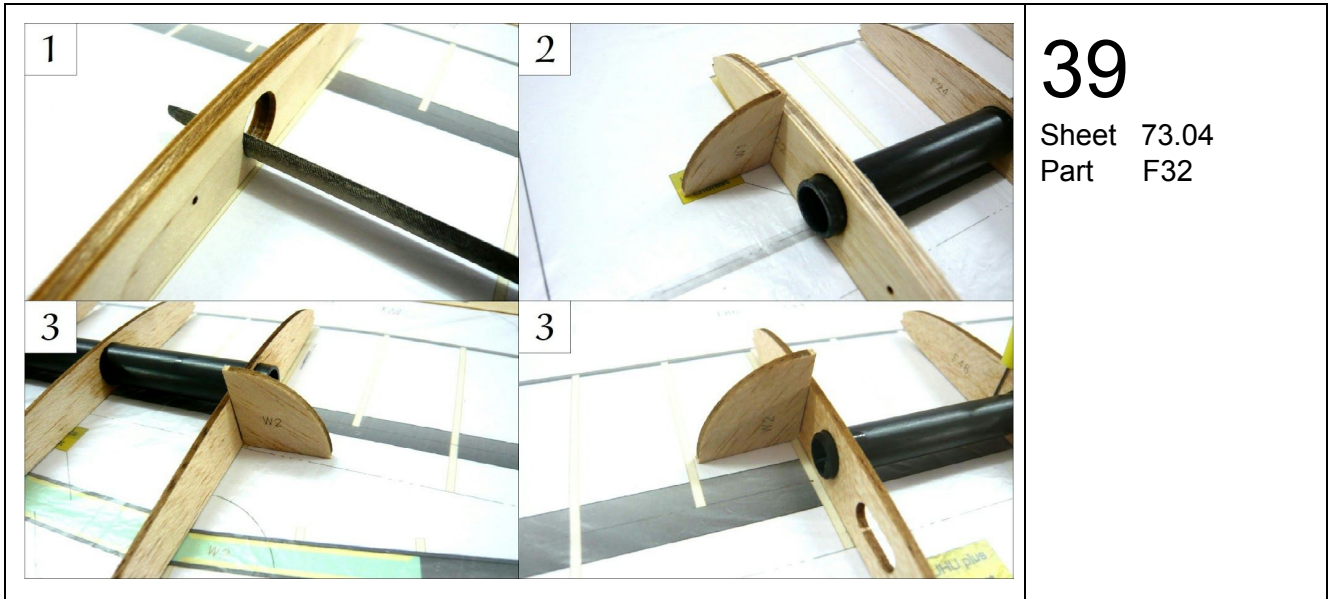

# 39

Sheet 73.04  
Part F32

- Using a small round file, shape the spar cut-out in the rib combination F22/F23/F22 to match the angle template W1. **WARNING:** Ensure that you make a **left-handed** and **right-handed** version.
- Glue the rib combination F22/F23/F22 to the trailing edge (thick CA) and to the spar (thin CA). Use template W1 to set the proper angle of the ribs.
- Dry fit rib F32. Shape the spar cut-out to match template W2 as required. Glue rib F32 to the trailing edge (thick CA) and to the spar (thin CA) using template W2 to ensure the correct angle.



# 40

Long parts bundle  
Part F13

Sheet 73.03  
Parts F34-42

- Glue leading edge F13 in place (thin CA).
- Glue in the half-ribs F34 to F42 aligning them carefully over the plan (thin CA).



# 41

Sheet 73.09  
Parts F83, F84

- Check-fit and trim reinforcements F83 and F84 as required and glue into place (thick CA).

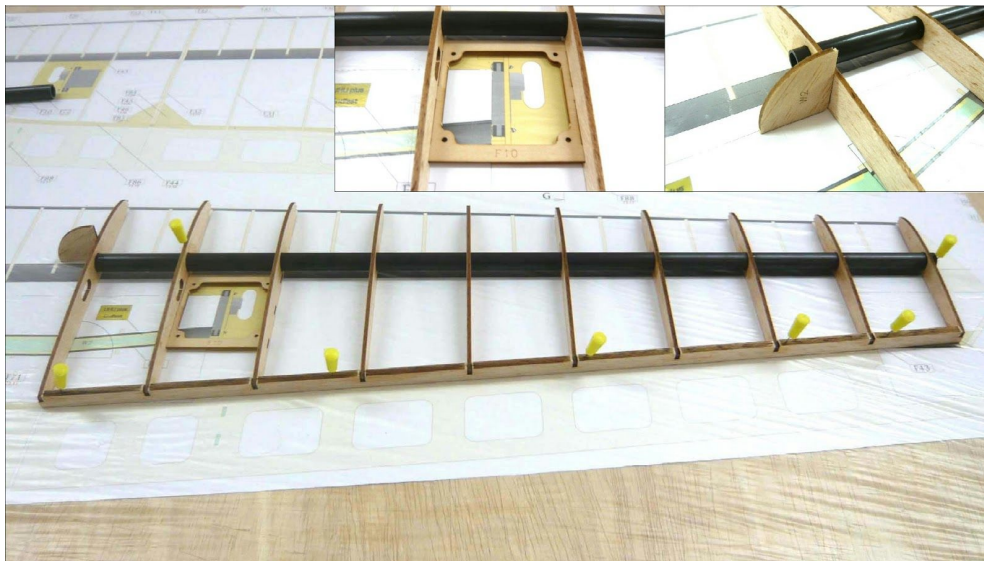

# 42

Long parts bundle  
Part F43

Sheet 73.04  
Parts F45-F54

Sheet 73.10  
Part F44

Sheet 73.11  
Part F10

- Slide ribs F46 to F54 on to spar F43.
- Insert servo mount frame F10 between ribs F46 and F47.
- Pin trailing edge F44 over the plan. **WARNING:** Observe the installation direction. The part identification "F44" should face towards the inner part of the wing and will eventually be covered by reinforcement F85.
- Align all ribs and glue to the trailing edge (thick CA) and the spar (thin CA).
- Glue rib F45 to the trailing edge (thin CA) and the spar (thick CA). Use angle template W2 to set the correct angle.
- Glue servo frame F10 in place (thin CA).

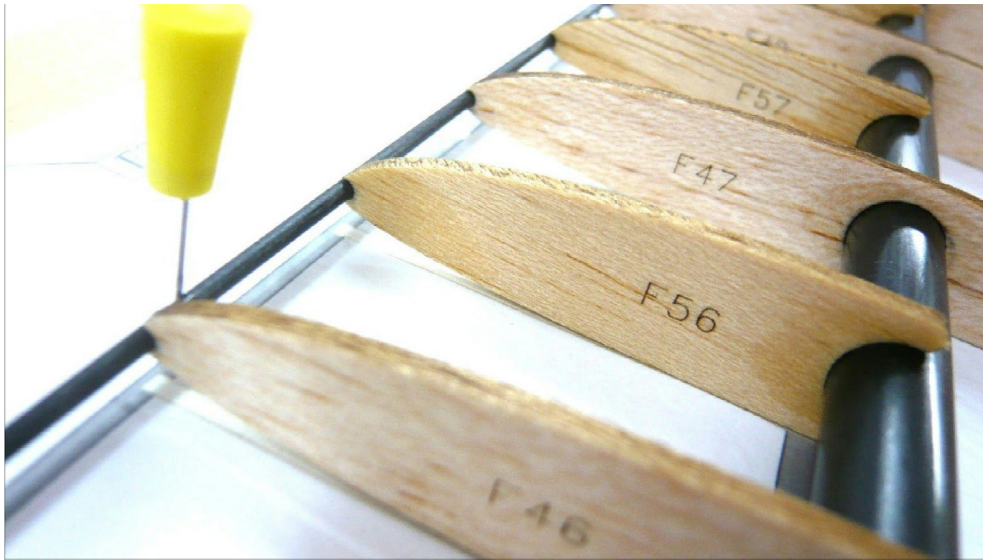

# 43

Long parts bundle  
Parts F13

Sheet 73.03  
Parts F55-F63

- Glue the leading edge F13 in place (thin CA).
- Glue the half ribs F55 to F63 in place (thin CA).
- Glue reinforcement F85 in place (thick CA).

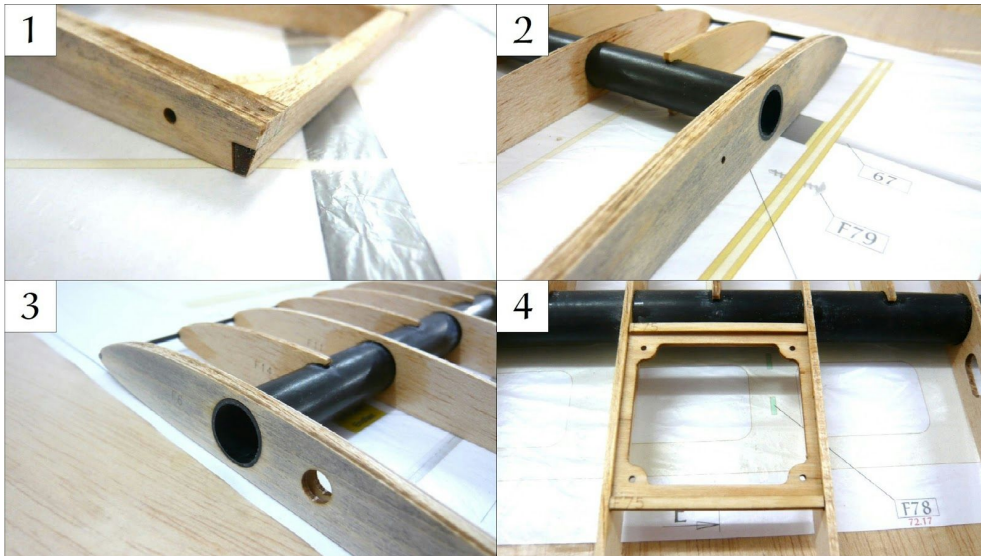

# 44

Sheet 73.11  
Part F75

- Figure 1 For all surfaces parts sand the ribs gently to the blend in with the trailing edge.
- Figure 2 -3 Sand spar tubes and leading edge flush with the end ribs.
- Figure 4 Sand the servo frame cross members, F75, flush with the frame/ribs.



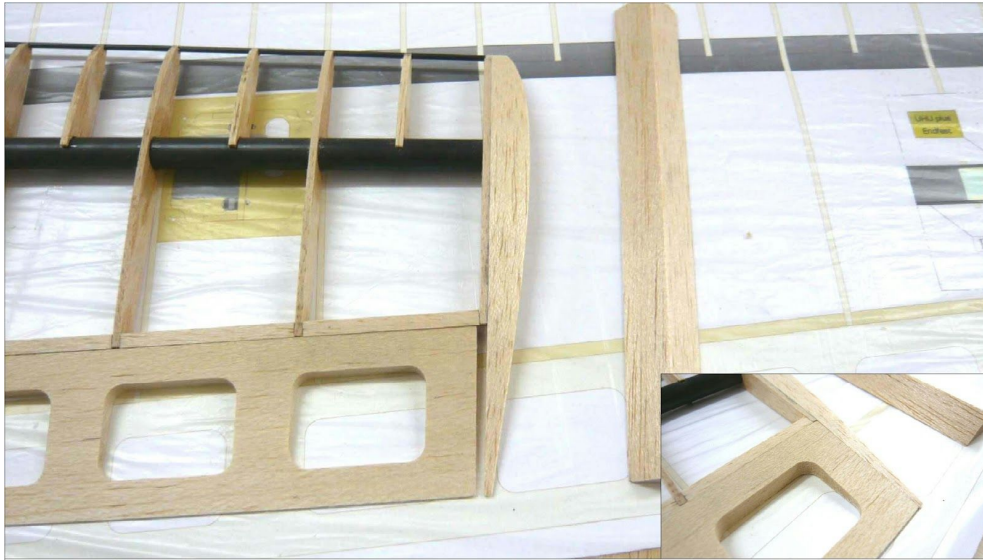

# 45

Part F69

Sheet 72.06

Part F70

- Cut F69 (stock triangular balsa bar) in the center to create the two wingtip braces.
- Glue the wing tip brace to the rib F54 flush with the lower edge of F54 (thick CA).
- Sand and/or plane the wingtip flush with the top of the rib. Use the aileron, F86, as a guide.
- Glue the wing tip F70 flush with the bottom edge of the outermost wing part.
- Sand the wing tips.

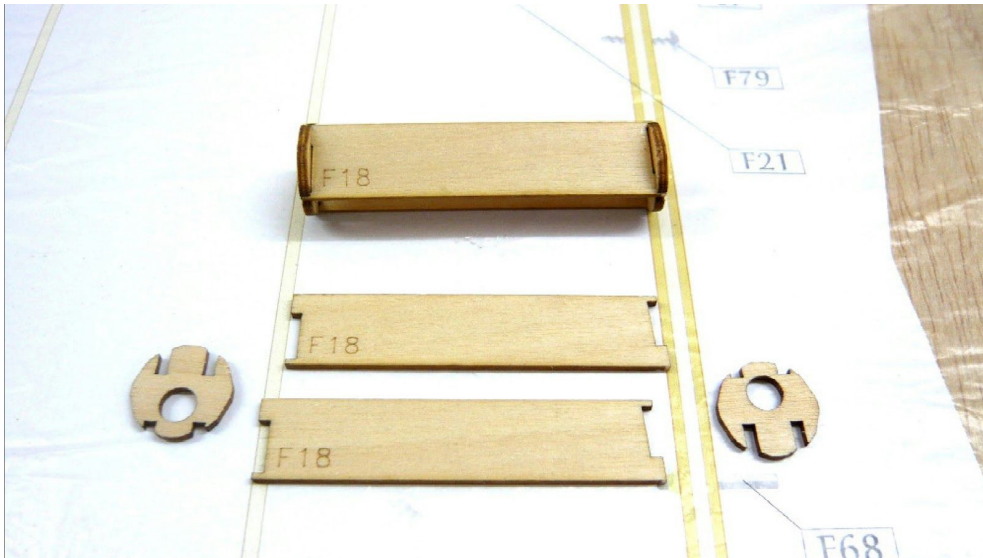

# 46

Sheet 73.11

Parts F18, F19

- For the wing joiner tube, glue F18 (2 pieces) and F19 (2 pieces) together (thick CA).

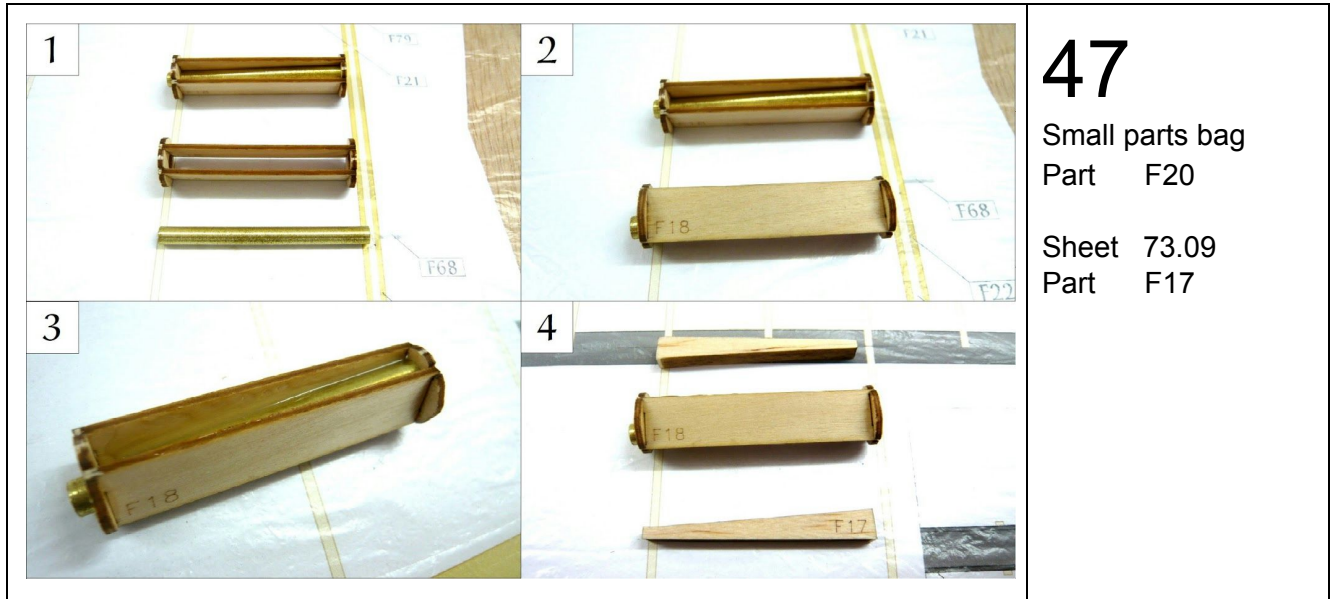

# 47

Small parts bag  
Part F20

Sheet 73.09  
Part F17

- Figure 1 Sand (roughen up) and degrease the brass tube F20.
- Figure 2 Slide the brass tube carefully into the holes in the wing joiner until the angled/skewed side is flush.
- Figure 3 Glue in the brass tube (90 minute epoxy).
- Figure 4 Check-fit, then glue two F17 fillers to retain the brass tube on one side of the wing joiner (thin CA). Repeat with the other two F17 fillers.

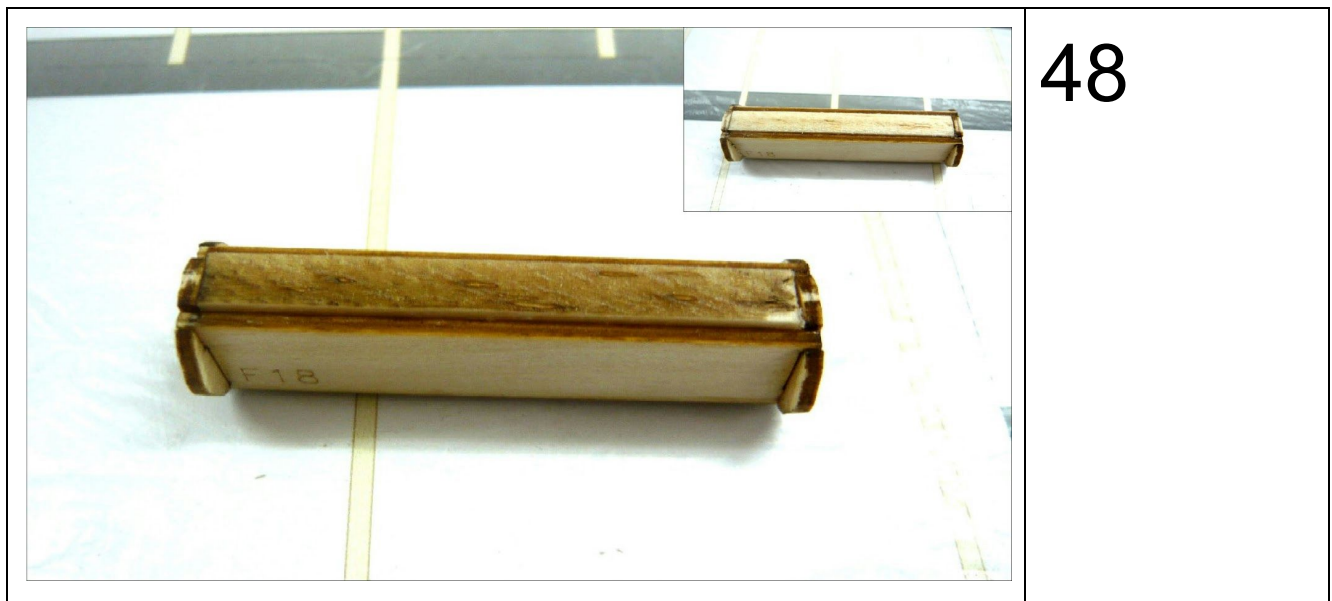

# 48

- Gently sand the holder to fit snugly, but not tightly, into the spar. **NOTE:** *Build experience from the EN translators suggests to make it slides in easily, too snugly might split/splice your spar!*

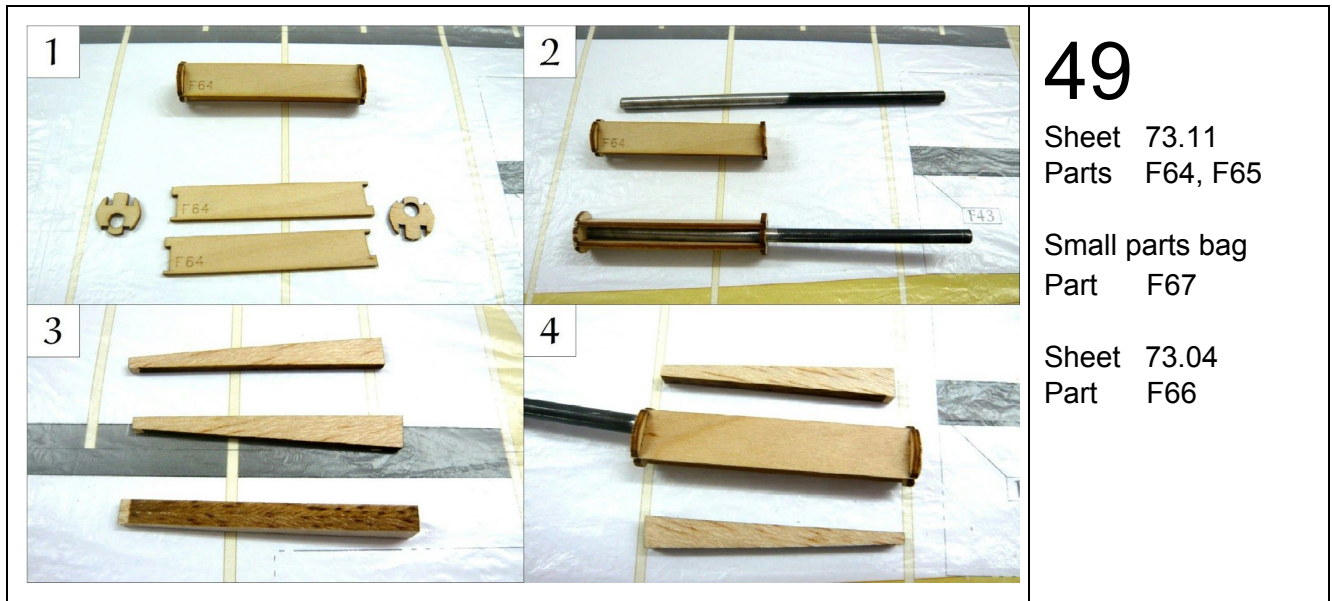

# 49

Sheet 73.11  
Parts F64, F65

Small parts bag  
Part F67

Sheet 73.04  
Part F66

- Figure 1 Shows the joiner for the outer wing sections. Glue parts F64 (2 pieces) and F65 (2 pieces) together (thick CA).
- Figure 2 Sand (roughen up) and degrease the joiner rod where it will be glue. Slide the joiner rod into the hole in the wing joiner tube, ensuring that it is correctly aligned. The rod should protrude approximately 1 mm from the straight end and 55 mm from the other. Glue the joiner tube in place (90 minutes epoxy).
- Glue two filler doublers F66 together (thick CA). Repeat for the other two filler doublers.
- Check-fit and glue these doublers to secure the joiner rod F67 (thin CA).

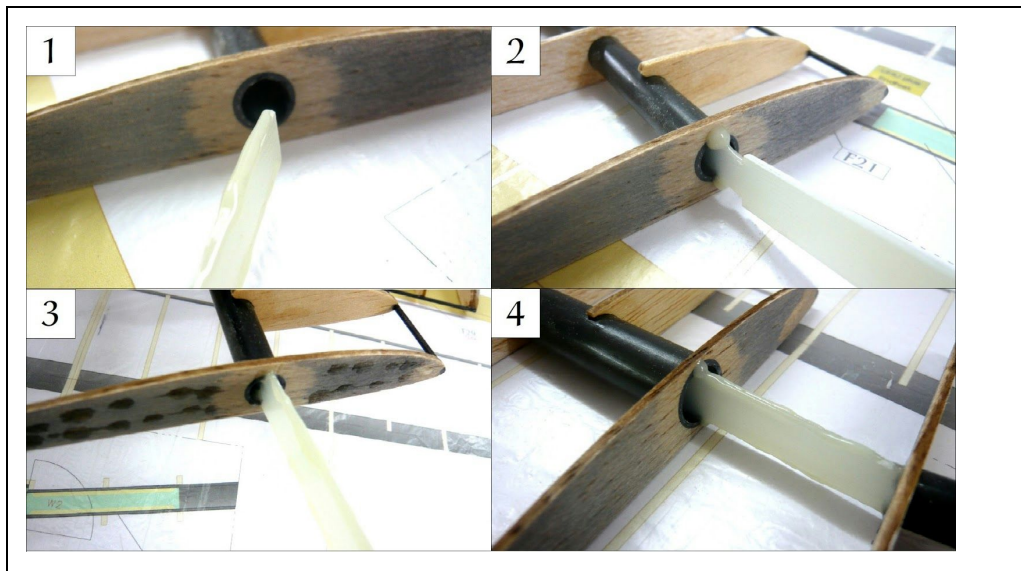

# 50

Sheet 72.17  
Part F71

- Sand the connector F71 at the splices so that it fits into the spars F21 and F43. **WARNING:** The connector should slide in easily, any force required may damage (splice) the spar. Remove the connector.
- Figure 1 Apply glue to the inside of the spar-tubes F21 and F43 (where the joiner will come to rest) edge of the connector piece on the thinner side.
- Figure 2 Insert the connector into the spar F43 (only the thinner side) and remove excess adhesive (90 minutes epoxy).

- Figure 3 Ensure correct vertical orientation of this spar connector until the epoxy sets.
- Figure 4 Apply glue to the faces of ribs F45 and F32 and the edges of the connector F71 that fit into spar F21 (90 minutes epoxy) and slide the wing sections over the wing connector, removing excess glue. Clamp ribs F45 and F32 until the epoxy sets.

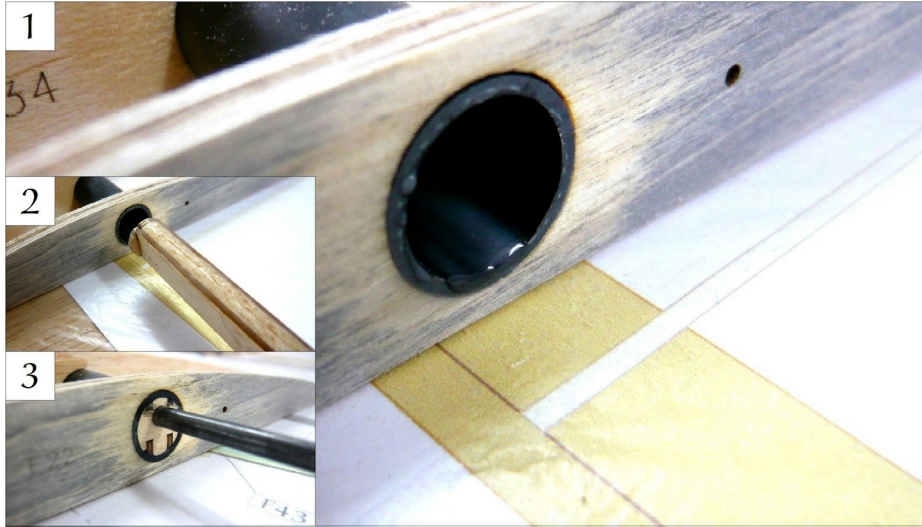

51

- Figure 1 Apply glue to the inside of the spar F21. Apply glue to the spar joiner rod assembly from step 49 (90 minutes epoxy).
- Figure 2 Slide the spar joiner rod assembly into F21 removing excess glue.
- Figure 3 Ensure the end of the joiner rod assembly is flush with the connecting rib and that the rod is aligned vertically.



52

- Figure 1 Seal the end of the wing joiner tube assembly by applying a transparent adhesive tape onto the protruding end of the tube, its side, and over the F19 end-piece. Trim tape flush around the F19 end-piece. This is to prevent glue from getting into the tube.

- Figure 2 Apply another piece of adhesive tape to the other end of the assembly (the beveled end). This is intended to prevent the assembly from sliding too far into the spar and also holds the assembly until the glue sets. Apply glue to the inside of spar F1 with a long stick. Apply glue to the wing tube joiner tube assembly. Insert assembly in the spar tube F1, sealed edge first (90 minutes epoxy). Remove excess glue.
- Figure 3 Align the spar tube assembly flush with the connecting rib and perpendicular using the tape to hold it in place. Leave to dry, and then remove the tape.

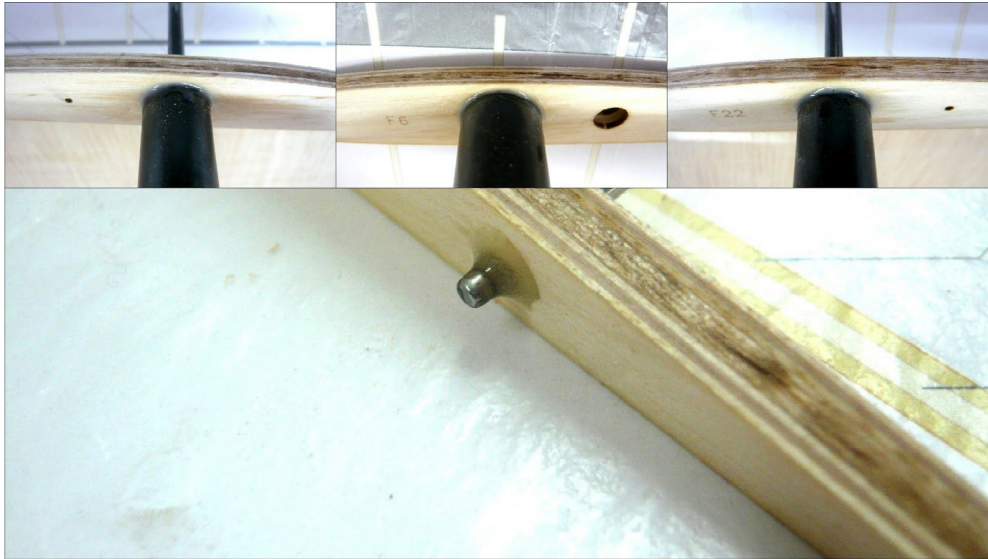

# 53

Small parts bag  
Part F68

- Check-fit alignment pin F68 into the holes in combined ribs F22/F23/F22. Ensure that it will mate with the matching hole in the combined ribs F6/F4/F6. Glue in place (90 minutes epoxy).
- Apply a fillet of epoxy to all joints between the spars and the connecting/end ribs (90 minutes epoxy).

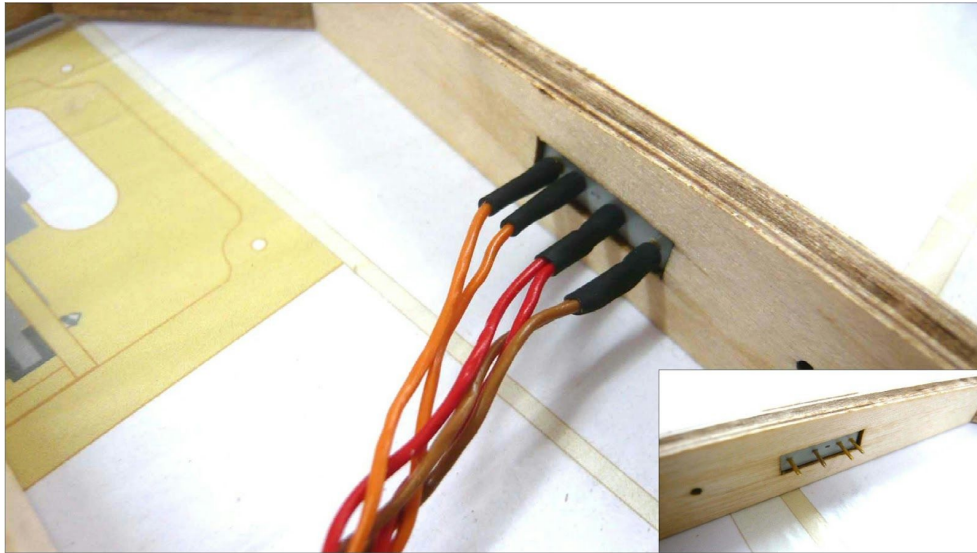

# 54

- Glue the black male Multiplex MPX 5-pin into the outer wing and the female into the wing midsection.
- Solder servo cables to the connectors and insulate with heat-shrink tubing.

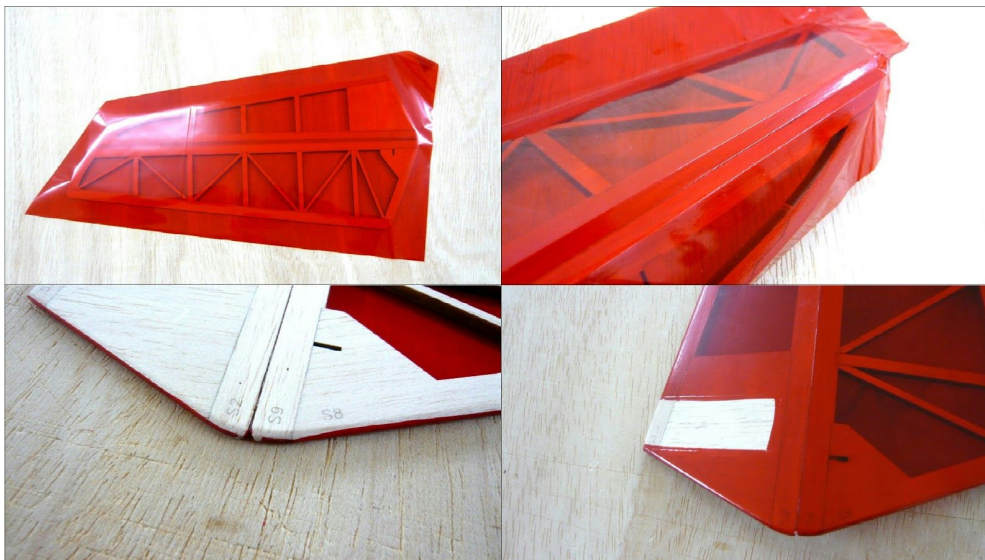

# 55

Rudder

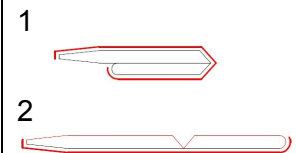

**COVERING :** In the method described here, the covering is applied through the hinge in one piece, which eliminates the need for a separate hinge.

- Cut two pieces of covering, one for each side of the rudder with about 2 cm overhang.
- With the right-hand faces of the rudder in contact, align the hinge line edges flush, and wrap one piece of film around the hinge line of the assembly. Iron onto the left-hand faces of the rudder. Ensure that there is good adhesion on the bevelled faces of the hinge (Figure 1). Cut off all outer edges with 3-5 mm excess and iron on.
- Iron the covering on the second side, rudder straight and flat, with a 3-5 mm excess overlapping the top side. Trim the excess and iron down (Figure 2).

- Remove covering where the piece will be glued to the fuselage, and where the horns will be glued.

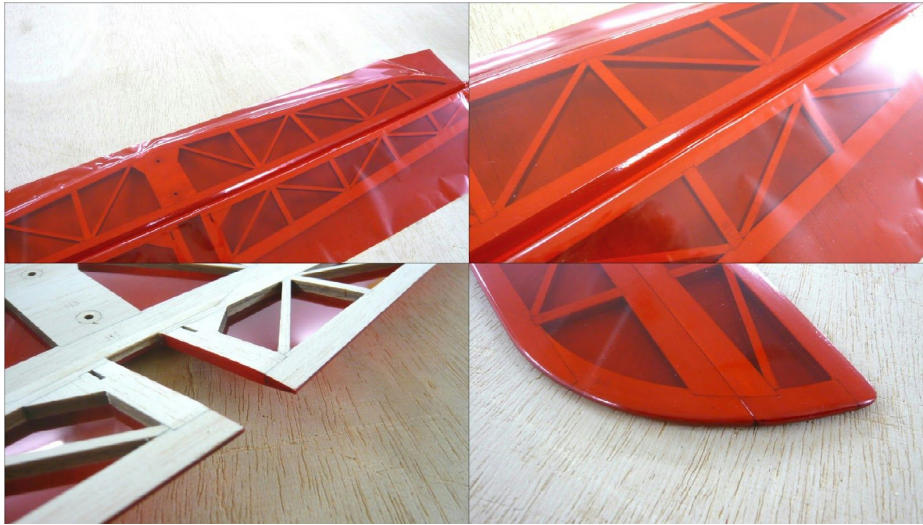

# 56

Elevator

1



2



- Cut the covering for both sides of the the elevator with about 2 cm overhang.
- First iron the covering on the side with the bevel and the pieces folded back on themselves (Figure 1). Cut and iron all outer edges with 3-5 mm excess.
- Iron the covering on the second side, again with 3-5 mm excess. The covering should overlap the first side and trim the excess (Figure 2).
- Remove covering where the piece will be glued to the fuselage.

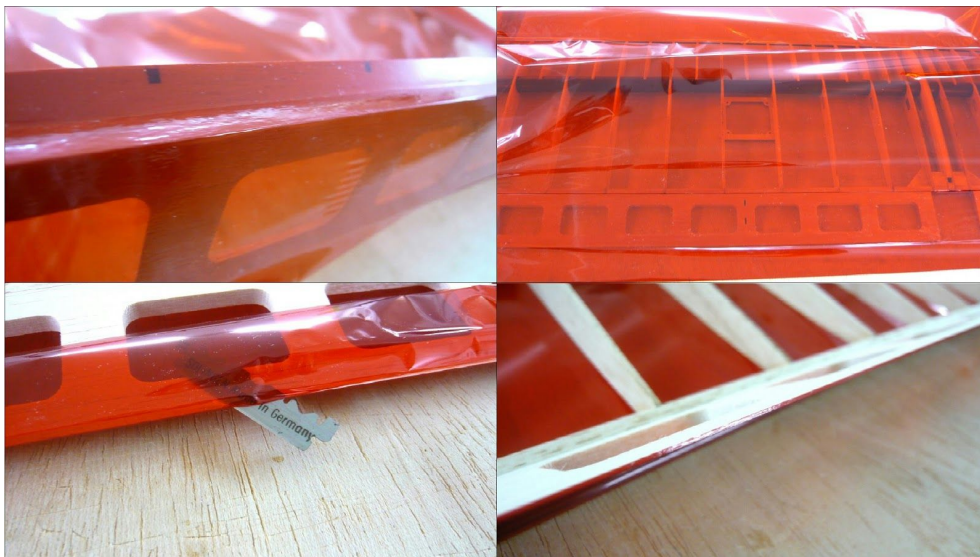

# 57

Wings

- The covering for the wing parts can be made in one piece. This saves attaching the covering to the thin leading edge.
- The flaps and hinges, as with the tail surfaces, can be covered as one piece with the wing.

- First attach the covering to the outer ends on top of the trailing edge F12. The overlap on the flap side should be about 9 cm. Iron the covering to the top of the trailing edge completely.
- Flip the flap completely over the bottom of the wing and iron the covering to the side of the trailing edge and the side of the flap, effectively forming the hinge. Trim to an overlap of 3mm at the edge of the flap and iron on.

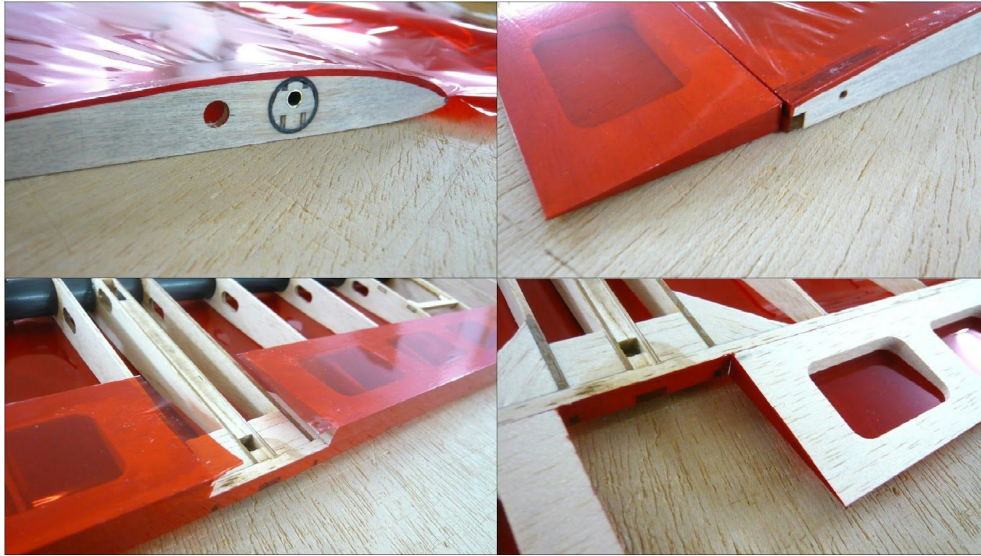

## 58

Wings

- Iron the covering to the top of the root rib. Trim overlap to 3 mm and iron to side of root rib.
- Iron covering on all outer edges of the flaps.

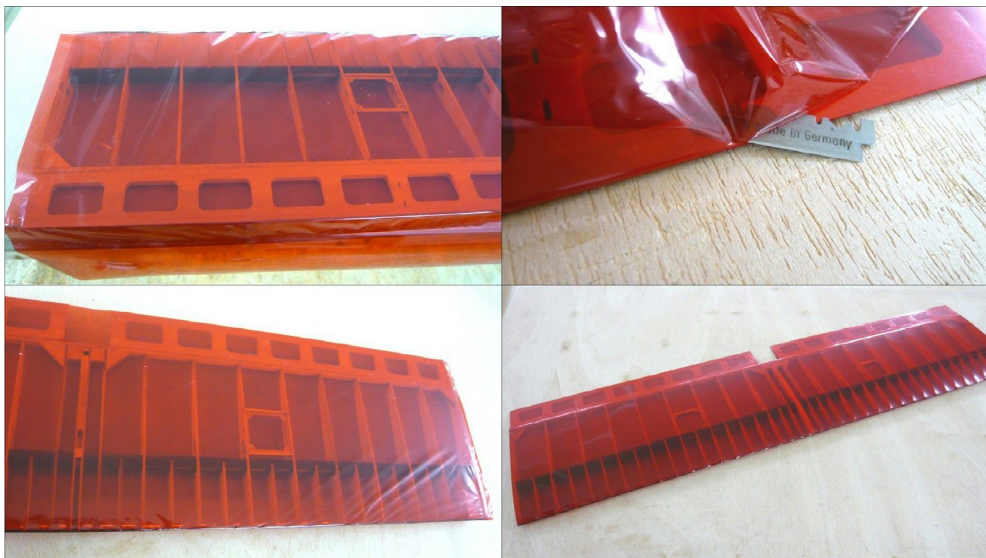

## 59



- Fold the covering over the leading edge and iron the covering to the trailing edge and onto the flaps.
- Iron the covering to the lower part of the root ribs, and cut off with 3 mm overlap
- Iron on all overhang.



- Shrink covering starting from the center, starting either from top or bottom. It is important that the covering has thorough adhesive contact to all ribs before shrinking.  
**WARNING:** Carefully heat-shrink the outermost panels to avoid warping of the center ribs.



# 60

Wings end sections

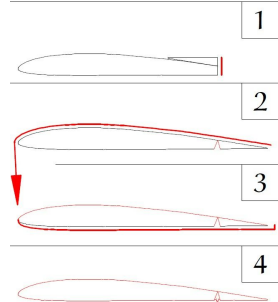

- The procedure for covering the outer wing panels is the same.
- Cut out the covering for all wing panel with enough overhang.
- Fix the ailerons with a small strip of covering (Figure 1)
- Iron the covering onto of the ailerons (completely), cut off with 3 mm overlap, and iron onto the top of the wing.
- Fold covering over the leading edge (Figure 2), and iron to the bottom of the wing up and including the aileron, with 3 mm overlap (Figure 3), ironing the overlap around the edge.
- Cut the bottom slot for the ailerons free (Figure 4) then iron the leftover.

**WARNING:** Carefully heat shrink the outermost panels to avoid warping the center ribs.

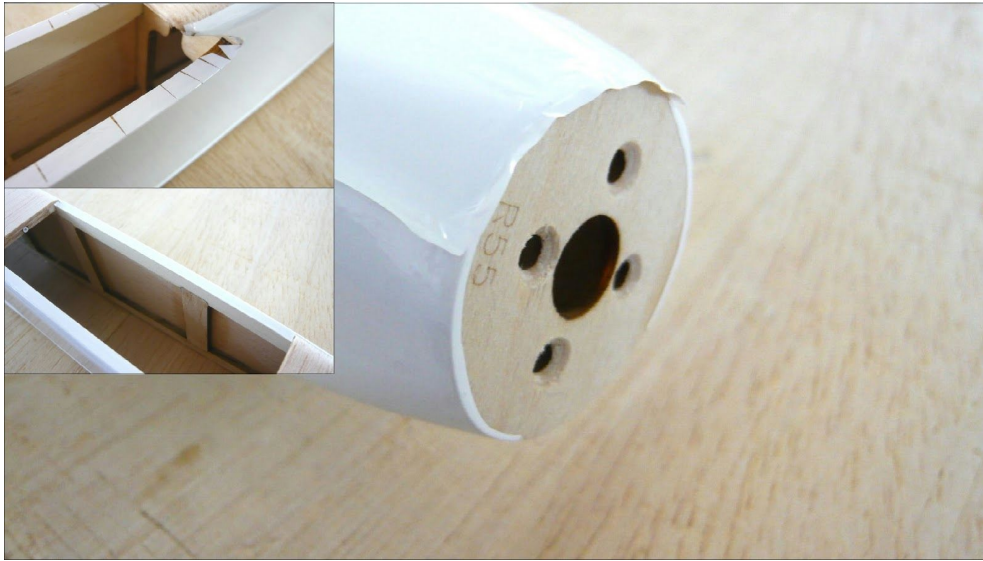

# 61

Fuselage

- First, cover the side-walls of the fuselage
- Cut covering for the sides of the fuselage with a 5 mm overlap at the top and bottom and a 2mm overlap/projection on the front. Iron the covering on including the overlap on the sides and the front. Slit and iron covering to fit in wing saddle and hatch opening (top left)
- **WARNING:** If the elevator is to be glued in place, do not cover the joining surface on the fuselage.
- Fuselage bottom covering. Cut the covering so that an overlap of approximately 3-5 mm is given. Ironing on the covering and overlaps.
- Cover the Canopy and battery hatch. Cut the film with an overlap of 3-5 mm and iron on.
- For the battery hatch cut the covering with a maximum of 2 mm overlap and iron on.

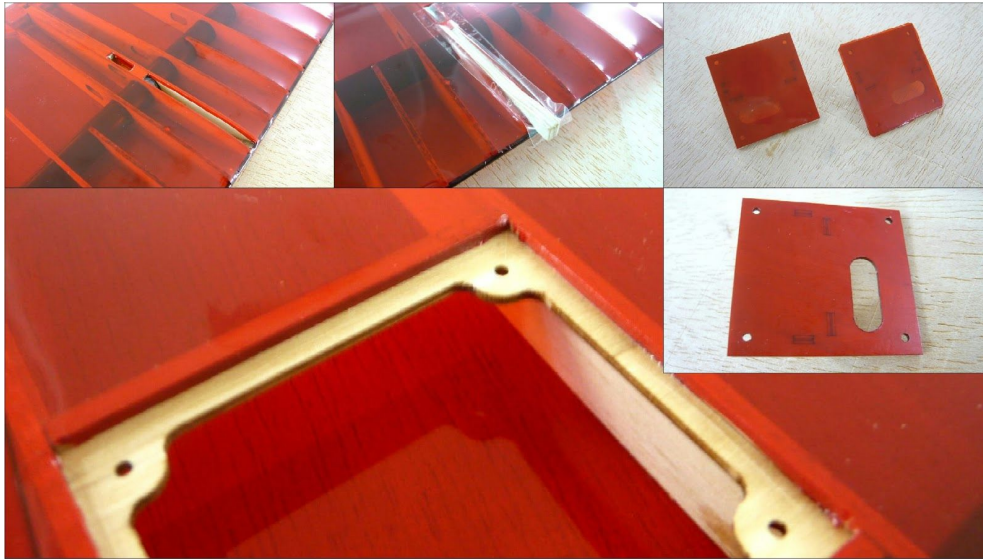

# 62

Sheet 73.11  
Part F82

- Cover the servo-cover. The openings for the servo arm and screw-holes can be cut with a hot soldering iron. You can also cut the holes for the servo hatch mounting screws and the oblong hole in the battery hatch.
  - Cut out the openings for the servos with 2 mm overlap and iron down the overlap.
  - Cut the covering flush to the slot in the center rib to make room for the wing anchorage F82.
  - Glue the wing anchorage F82 by stacking all three parts so they align well (thick CA).
  - Glue the wing anchorage F82 and secure with tape (90 minutes epoxy).
- WARNING:** Pay attention to ensure there is a good adhesive bond in the whole-area. The top of the front pin has to touch the leading edge.

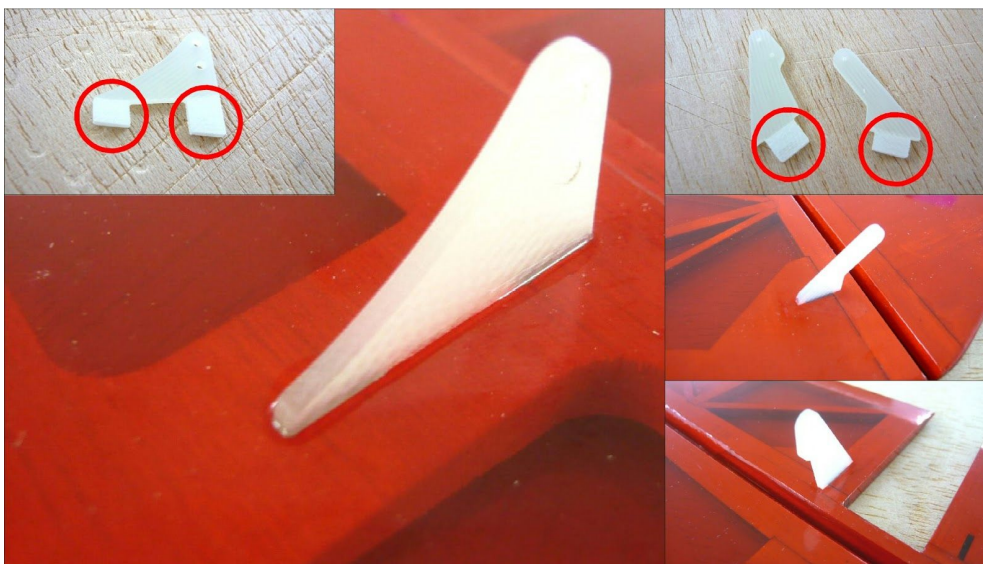

# 63

Sheet 73.17  
Parts F78, F88,  
H27, S23

- Cut slots in the covering material for the horns on the control surface.
- Sand the horn's tabs as shown in the figures (red circles).
- Insert into the slots and glue the horns F78 (spoilers) and F88 (aileron inside and outside) (thin CA).

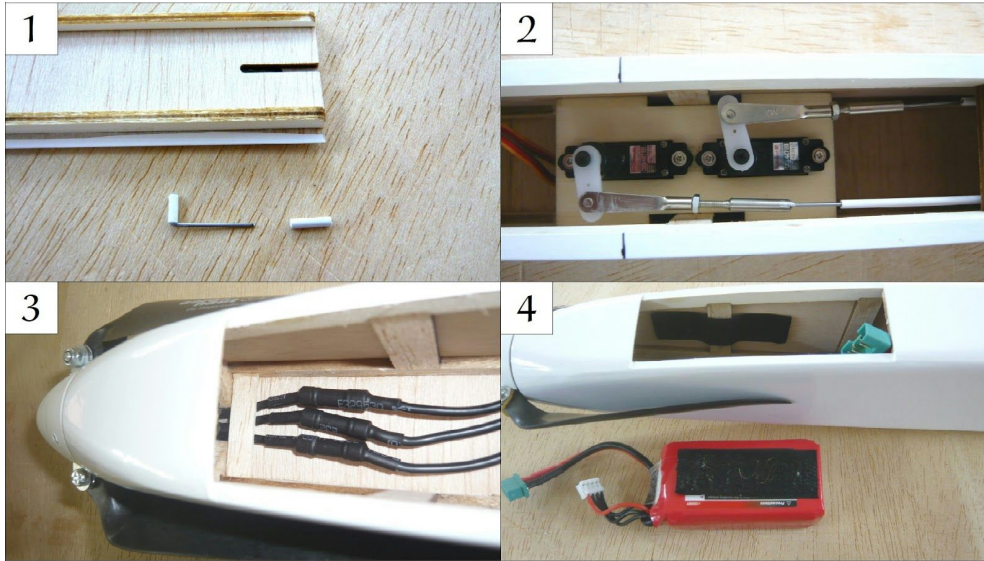

# 64

Long pieces bundle  
Part R56

Small parts  
Parts R58, R59,  
R60, R65

Sheet 72.14  
Part R57

- Figure 1 Establish the hatch lock from a scrap piece of guide tube R56 and cable R29 and glue it in the battery hatch. (5 minutes epoxy).  
**WARNING:** Do not allow adhesive into the guide tube. When using the magnetic closure, use bar magnet R65; Check the polarity of the magnet when gluing in place of the wire lock.
- Figure 2 Sand and clean the ends of the cables R56 for rudder and elevator control rods. Solder a threaded coupler R59 on the end of the control rods and then add a nut R60 and clevis R58. Install the servo tray and servos and adjust the control rods/cables.
- Figure 3 Motor installation. Use a small 2 mm piece of balsa to hold the motor wires (thick CA). The propeller and the spinner are mounted only after the adjustments.
- Figure 4 Use velcro to attach the battery to the fuselage side wall.

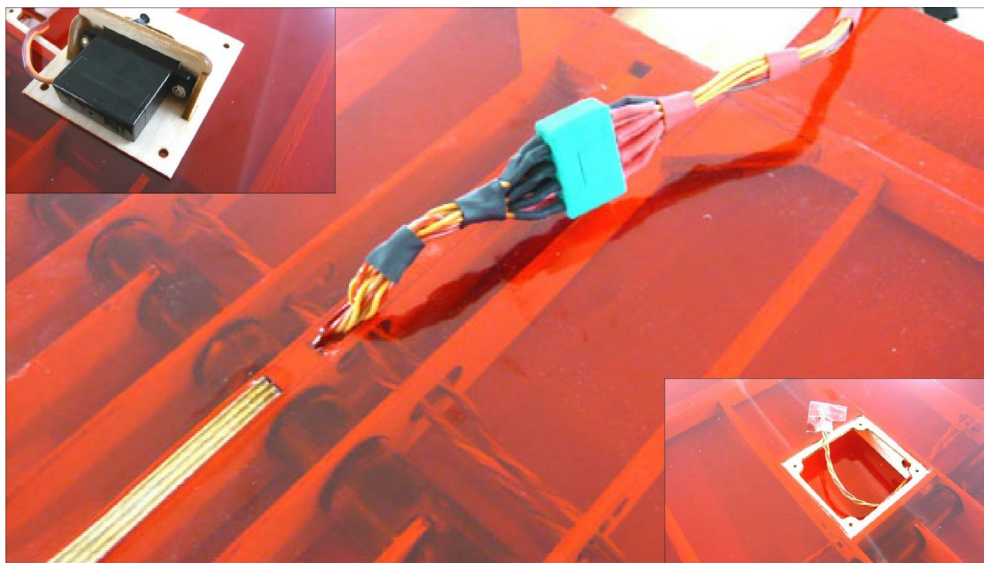

# 65

Long pieces bundle  
Parts R56

Small parts bag  
Parts R58, R59,  
R60, F76

- Secure the servo cable with tape to avoid inadvertently withdrawing it.
- Solder the 8 pin connector. Refer to the wiring diagram (step 67).
- The wing-mounted servo cables can be soldered directly to the servo extension.

- Attach servos to the servo frames.
- Make servo linkages from the remaining of the servo rods R56, clean ends and solder on a threaded coupler R59, then add nut R60 and clevises R58. Adjust servo arm and linkages to fit the appropriate control surface. See step 69 for throws adjustments, or plan sections E, G and H.
- Mount the servo cover with screws F76.



# 66

Long pieces bundle  
Part R29

- Glue and align the rudder.
- Glue or screw and align the elevator.
- Trim the control rods to length at the rear control horns. A small piece of guide tube can be glued to the end of the bend to secure it.
- For a detachable tailplane, create a Z bend in the end of the control rod.
- If needed, glue small remnants of the control rod guide tube R29 to the side of the fuselage for the receiver antennas (5 minute epoxy).

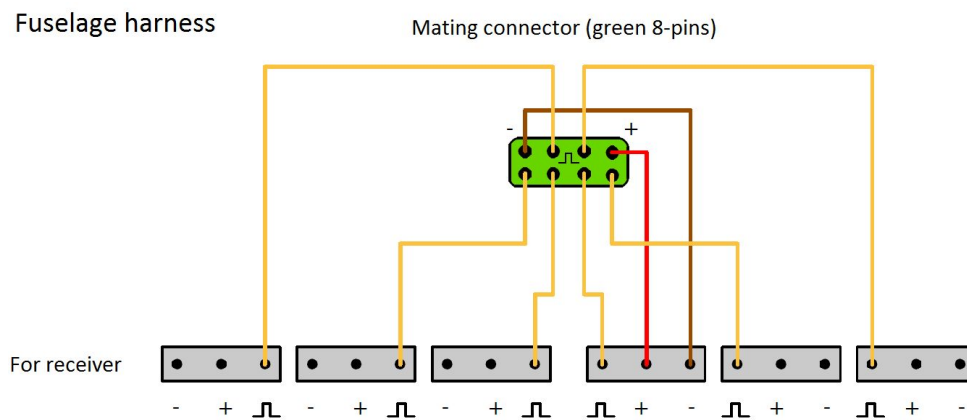
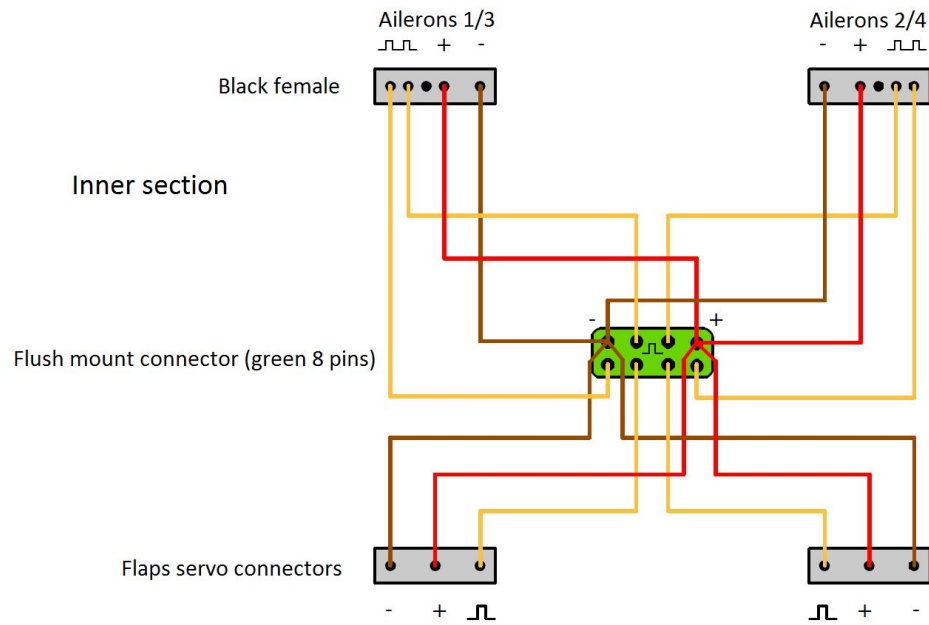
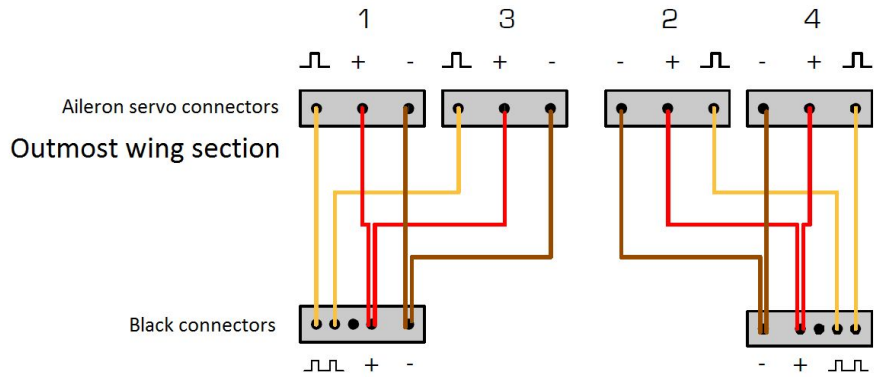

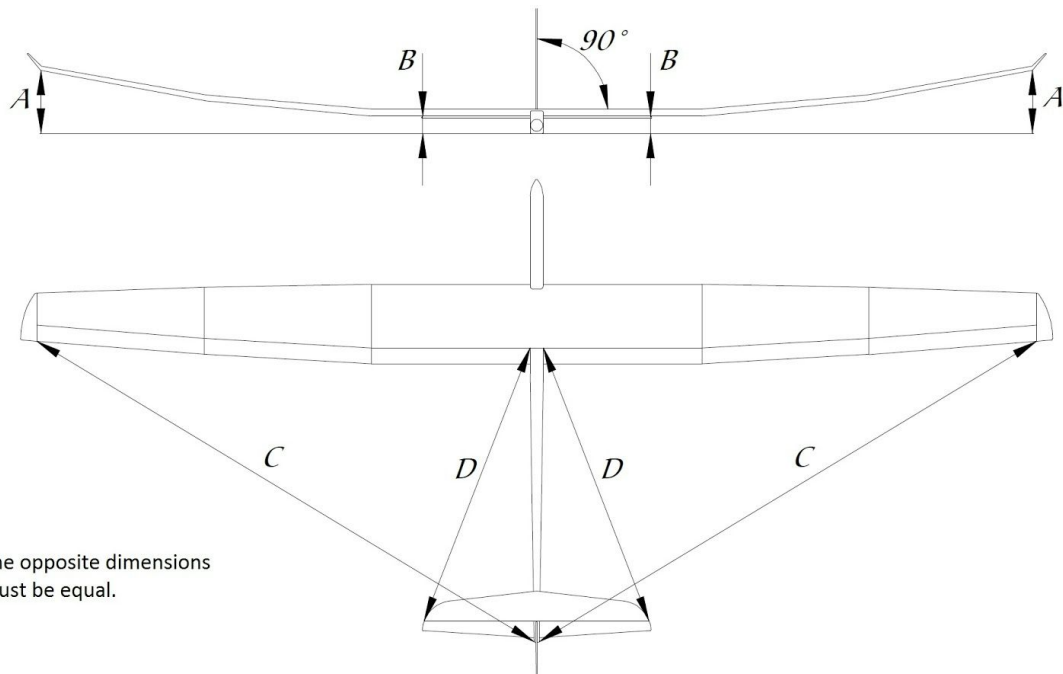

**Control surface throws**

- Elevator +/- 15 mm
- Rudder +/- 60 mm
- Inside aileron +/- 6 mm
- Outer aileron +/- 6 mm
- Flaps 70-90 degrees
- Thermals: flaps and ailerons inside and outside 2 mm down
- Speed: ailerons inside and outside 2 mm upwards

**Center of Gravity (CG):**

- The CG is 87 to 90 mm behind the leading edge. For the first few flights we recommend setting the CG to 87 mm. For higher performance, the CG may be set to 90 mm. Move the flight battery as needed to adjust CG. Optionally trim weight can be used.
- Charge all batteries before flying. The recommended flight battery will give up to one hour flight time with no thermals.

**WARNING:** Land before battery voltage gets too low.

**Flying:**

- Test the model initially by throwing it into the wind. Trim to make sure that it flies properly. Once the gliding testing is done and everything is okay the motor can be used.
- When using the motor sometimes it is necessary to use down elevator. This can be trimmed out by using a mix/launch mode on the radio to compensate.
- Flaps can be used for a rapid descent from a height.
- With extended flaps, down elevator must be used. A mix can be programmed into the radio for this. With the stated flight weight and with correct flap/aileron settings and mixes it is possible to do steep descents without excessive airspeed.
- Shortly before landing retract the flaps to avoid possible damage to the servo gears.
- Have fun while building and flying.



This assembly instruction is part of the product. If you pass on the product to a third party, please pass on this manual.